

Introduction to particle physics: Experimental part

Akcelerators

Experiment = probing theories with data

$$\begin{aligned}
 & -\frac{1}{2}\partial_\nu g_\mu^\nu \partial_\rho g_\mu^\rho - g_s f^{abc} \partial_\mu g_\rho^a g_\nu^b g_\mu^c - \frac{1}{2}g_s^2 f^{abc} f^{ade} g_\mu^b g_\nu^c g_\rho^d g_\mu^e + \\
 & \frac{1}{2}g_s^2 (q_i^\mu \gamma^\mu q_j^\nu) g_\mu^a + G^a \partial^\mu G^a + g_s f^{abc} \partial_\mu G^a G^b G^c - \partial_\mu W_\nu^+ \partial_\nu W_\mu^- - \\
 & M^2 W_\mu^+ W_\mu^- - \frac{1}{2}\partial_\nu Z_\mu^0 \partial_\nu Z_\mu^0 - \frac{1}{2}M^2 Z_\mu^0 Z_\mu^0 - \frac{1}{2}\partial_\mu A_\nu \partial_\nu A_\mu - \frac{1}{2}\partial_\mu H \partial_\nu H - \\
 & \frac{1}{2}m_h^2 H^2 - \partial_\mu \phi^+ \partial_\mu \phi^- - M^2 \phi^+ \phi^- - \frac{1}{2}\partial_\mu \phi^0 \partial_\mu \phi^0 - \frac{1}{2}M^2 \phi^0 \phi^0 - \beta_h \frac{[2M^2]}{2} + \\
 & \frac{2M^2}{\Lambda} H + \frac{1}{\Lambda} (H^2 + \phi^0 \phi^0 + 2\phi^+ \phi^-) + \frac{2M^2}{\Lambda} \alpha_h - ig_{c_w} [\partial_\nu Z_\mu^0 (W_\mu^+ W_\nu^- - \\
 & W_\mu^- W_\nu^+) - Z_\mu^0 (W_\mu^+ \partial_\nu W_\mu^- - W_\nu^- \partial_\mu W_\mu^+) + Z_\mu^0 (W_\mu^+ \partial_\nu W_\mu^- - \\
 & W_\nu^- \partial_\mu W_\mu^+) - ig_{s_w} [\partial_\nu A_\mu (W_\mu^+ W_\nu^- - W_\nu^- W_\mu^+) - A_\nu (W_\mu^+ \partial_\nu W_\mu^- - \\
 & W_\nu^- \partial_\mu W_\mu^+) + A_\mu (W_\mu^+ \partial_\nu W_\nu^- - W_\nu^- \partial_\mu W_\mu^+) - \frac{1}{2}g^2 W_\mu^+ W_\nu^- W_\nu^+ W_\mu^- + \\
 & \frac{1}{2}g^2 W_\mu^+ W_\nu^- W_\nu^+ W_\mu^- + g^2 c_w^2 (Z_\mu^0 W_\nu^+ Z_\nu^0 W_\mu^-) + g^2 s_w^2 (W_\mu^+ W_\nu^-) + \\
 & g^2 s_w^2 (A_\mu W_\nu^+ A_\nu W_\mu^- - A_\mu A_\nu W_\nu^+ W_\mu^-) + g^2 s_w c_w [A_\mu Z_\nu^0 (W_\mu^+ W_\nu^- - \\
 & W_\nu^- W_\mu^+) - 2A_\mu Z_\mu^0 W_\nu^+ W_\nu^-] - g\alpha [H^2 + H\phi^0 \phi^0 + 2H\phi^+ \phi^-] - \\
 & \frac{1}{8}g^2 \alpha_h [H^4 + (\phi^0)^4 + 4(\phi^0)^2 \phi^+ \phi^- + 4H^2 \phi^+ \phi^- + 2(\phi^0)^2 H^2] - \\
 & g M W_\mu^+ W_\nu^- H - \frac{1}{2}g \frac{M}{c_w} Z_\mu^0 Z_\nu^0 H - \frac{1}{2}ig W_\mu^+ (\partial_\nu \phi^0 \phi^- - \phi^- \partial_\nu \phi^0) - \\
 & W_\nu^- (\phi^0 \partial_\nu \phi^+ - \phi^+ \partial_\nu \phi^0) + \frac{1}{2}ig [W_\mu^+ (H\partial_\nu \phi^- - \phi^- \partial_\nu H) - W_\nu^- (H\partial_\nu \phi^+ - \\
 & \phi^+ \partial_\nu H)] + \frac{1}{2}g \frac{1}{c_w} (Z_\mu^0 H\partial_\nu \phi^0 - \phi^0 \partial_\nu H) - ig \frac{2s_w}{c_w} M Z_\mu^0 (W_\mu^+ \phi^- - W_\nu^- \phi^+) + \\
 & ig_{s_w} M A_\mu (W_\mu^+ \phi^- - W_\nu^- \phi^+) - ig \frac{1-2c_w^2}{2c_w} Z_\mu^0 (\phi^+ \partial_\nu \phi^- - \phi^- \partial_\nu \phi^+) - \\
 & ig_{s_w} A_\mu (\phi^+ \partial_\nu \phi^- - \phi^- \partial_\nu \phi^+) - \frac{1}{2}g^2 W_\mu^+ W_\nu^- [H^2 + (\phi^0)^2 + 2\phi^+ \phi^-] - \\
 & \frac{1}{4}g^2 \frac{1}{c_w} Z_\mu^0 Z_\nu^0 [H^2 + (\phi^0)^2 + 2(2s_w^2 - 1)\phi^+ \phi^-] - \frac{1}{2}g^2 \frac{2s_w}{c_w} Z_\mu^0 \phi^0 (W_\mu^+ \phi^- + \\
 & W_\nu^- \phi^+) - \frac{1}{2}ig^2 \frac{2s_w}{c_w} Z_\mu^0 H (W_\mu^+ \phi^- - W_\nu^- \phi^+) + \frac{1}{2}g^2 s_w A_\mu \phi^0 (W_\mu^+ \phi^- + \\
 & W_\nu^- \phi^+) + \frac{1}{2}ig^2 s_w A_\mu H (W_\mu^+ \phi^- - W_\nu^- \phi^+) - g^2 \frac{2s_w}{c_w} (2c_w^2 - 1) Z_\mu^0 A_\mu \phi^+ \phi^- - \\
 & g^2 s_w^2 A_\mu A_\nu \phi^+ \phi^- - e^2 (\gamma \partial + m_\nu^2) e^\lambda - \rho^2 \gamma \partial \nu^\lambda - u_\nu^2 (\gamma \partial + m_\nu^2) u_\nu^\lambda + \\
 & d_\nu^2 (\gamma \partial + m_\nu^2) d_\nu^\lambda + ig_{s_w} A_\mu [-(e^\lambda \gamma^\mu e^\lambda) + \frac{2}{3}(u_\nu^2 \gamma^\mu u_\nu^2) - \frac{1}{3}(d_\nu^2 \gamma^\mu d_\nu^2)] + \\
 & \frac{ig}{4c_w} Z_\mu^0 [(\nu^\lambda \gamma^\mu (1 + \gamma^5) \nu^\lambda) + (e^\lambda \gamma^\mu (4s_w^2 - 1 - \gamma^5) e^\lambda) + (u_\nu^2 \gamma^\mu (\frac{2}{3}s_w^2 - \\
 & 1 - \gamma^5) u_\nu^2) + (d_\nu^2 \gamma^\mu (1 - \frac{2}{3}s_w^2 - \gamma^5) d_\nu^2)] + \frac{ig}{2\sqrt{2}} W_\mu^+ [(\nu^\lambda \gamma^\mu (1 + \gamma^5) \nu^\lambda) + \\
 & (u_\nu^2 \gamma^\mu (1 + \gamma^5) C_{\lambda\nu} d_\nu^\lambda) + \frac{ig}{2\sqrt{2}} W_\mu^- [(e^\lambda \gamma^\mu (1 + \gamma^5) e^\lambda) + (\bar{d}_\nu^2 C_{\lambda\nu} \gamma^\mu (1 + \\
 & \gamma^5) u_\nu^2)] + \frac{ig}{2\sqrt{2}} \frac{m_\nu^2}{M} [-\phi^+ (\nu^\lambda (1 - \gamma^5) e^\lambda) + \phi^- (e^\lambda (1 + \gamma^5) \nu^\lambda)] - \\
 & \frac{ig}{2} \frac{m_\nu^2}{M} [H (e^\lambda e^\lambda) + i\phi^0 (e^\lambda \gamma^5 e^\lambda)] + \frac{ig}{2M\sqrt{2}} \phi^+ [-m_\nu^2 (u_\nu^2 C_{\lambda\nu} (1 - \gamma^5) d_\nu^\lambda) + \\
 & m_\nu^2 (u_\nu^2 C_{\lambda\nu} (1 + \gamma^5) d_\nu^\lambda) + \frac{ig}{2M\sqrt{2}} \phi^- [m_\nu^2 (d_\nu^2 C_{\lambda\nu} (1 + \gamma^5) u_\nu^2) - \\
 & m_\nu^2 (d_\nu^2 C_{\lambda\nu} (1 - \gamma^5) u_\nu^2)] - \frac{ig}{2} \frac{m_\nu^2}{M} H (u_\nu^2 u_\nu^2) - \frac{ig}{2} \frac{m_\nu^2}{M} \phi^0 (u_\nu^2 \gamma^0 u_\nu^2) - \\
 & \frac{ig}{2M} \phi^0 (\bar{d}_\nu^2 \gamma^0 d_\nu^2) + \bar{X}^+ (\partial^\mu - M^2) X^+ + \bar{X}^- (\partial^\mu - M^2) X^- + \bar{X}^0 (\partial^\mu - \\
 & \frac{M^2}{c_w}) X^0 + \bar{Y} \partial^\mu Y + ig_{c_w} W_\mu^+ (\partial_\nu \bar{X}^0 X^- - \partial_\nu \bar{X}^+ X^0) + ig_{s_w} W_\mu^+ (\partial_\nu \bar{Y} X^- - \\
 & \partial_\nu \bar{X}^+ Y) + ig_{c_w} W_\mu^- (\partial_\nu \bar{X}^- X^0 - \partial_\nu \bar{X}^0 X^+) + ig_{s_w} W_\mu^- (\partial_\nu \bar{X}^- Y - \\
 & \partial_\nu \bar{Y} X^+) + ig_{c_w} Z_\mu^0 (\partial_\nu \bar{X}^+ X^- - \partial_\nu \bar{X}^- X^0) + ig_{s_w} A_\mu (\partial_\nu \bar{X}^+ X^- + \\
 & \partial_\nu \bar{X}^- X^0) - \frac{1}{2}ig M [\bar{X}^+ X^+ H + \bar{X}^- X^- H + \frac{1}{c_w} \bar{X}^0 X^0 H] + \\
 & \frac{1-2c_w^2}{2c_w} ig M [\bar{X}^+ X^0 \phi^+ - \bar{X}^- X^0 \phi^-] + \frac{1}{2c_w} ig M [\bar{X}^0 X^- \phi^+ - \bar{X}^+ X^+ \phi^-] + \\
 & ig M s_w [\bar{X}^0 X^- \phi^+ - \bar{X}^+ X^+ \phi^-] + \frac{1}{2}ig M [\bar{X}^+ X^+ \phi^0 - \bar{X}^- X^- \phi^0]
 \end{aligned}$$

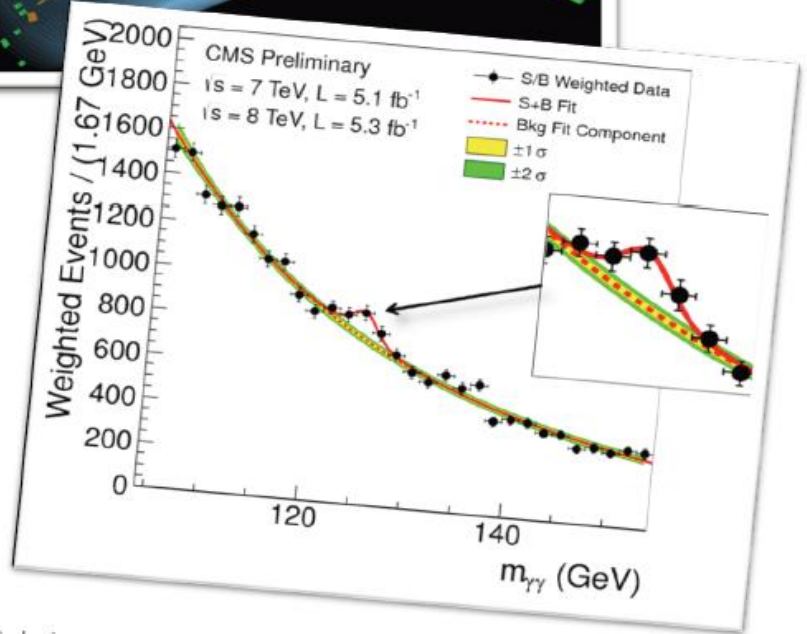
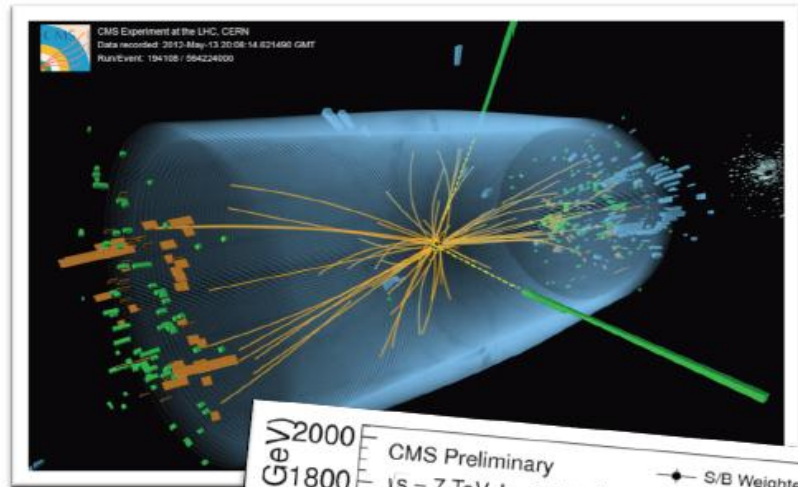

- Delamater

(experimental) LHC physics

Why accelerating and colliding particles

Aren't natural radioactive processes enough? What about cosmic rays?

High energy

$$E = mc^2$$

- Probe smaller scale
- Produce heavier particles

Large number of collisions

$$N = \mathcal{L} \cdot \sigma$$

- Detect rare processes
- Precision measurements

What particle to accelerate and collide

- **Stable (charged) particle**

- ✓ Electron/positron

- ✓ Proton/antiproton



what particle should we use?

- **Secondary beams of charged or neutral particles**

- ✓ (Anti)neutrinos

- ✓ Muons

- ✓ Photons

- ✓ Charged pions

- ✓ Kaons

- ✓ ...

Energy frontiers

- **Historical progress has been like power law for most of the last 70 years**
 - Vast majority of recent machines were synchrotrons
 - Notable exceptions
 - SLC
 - NLC/ILC

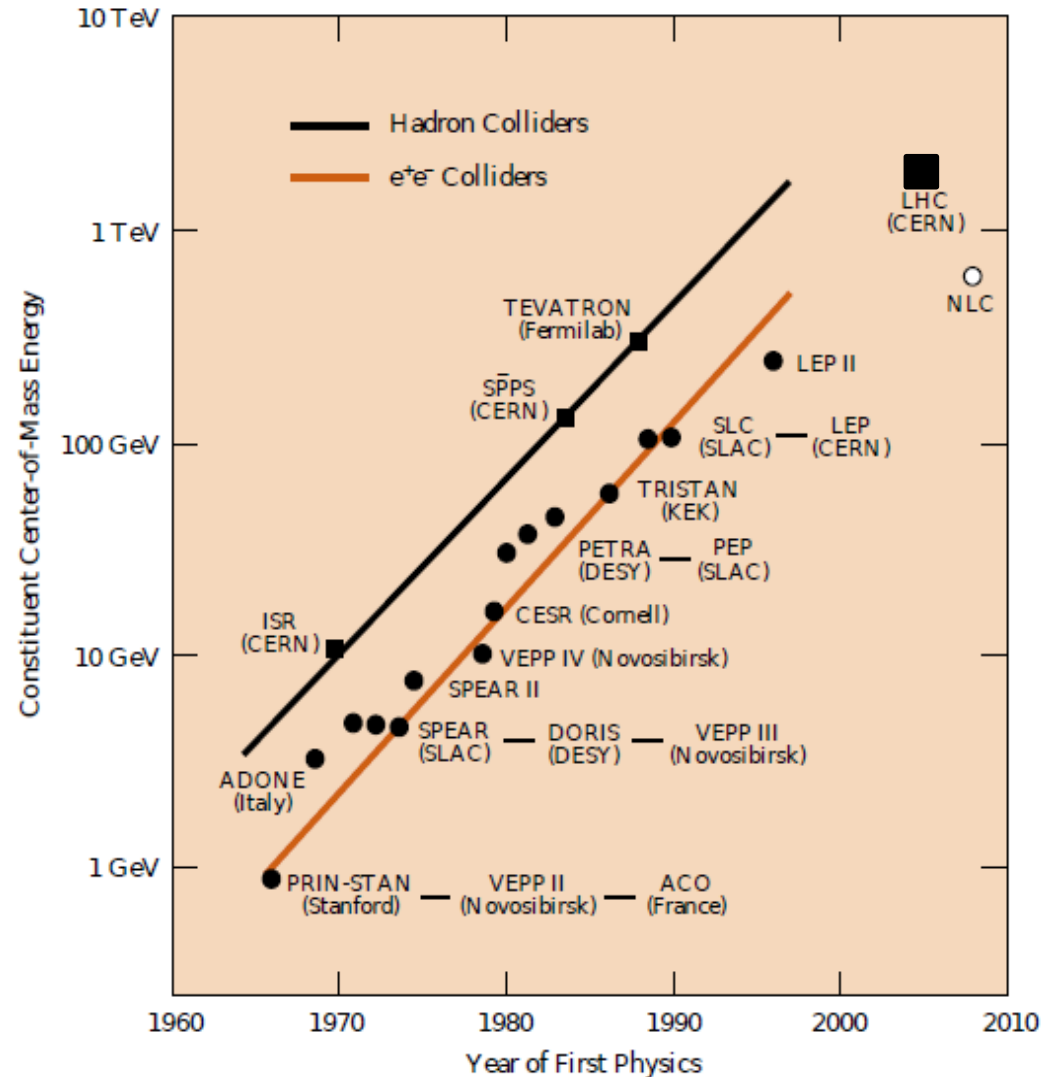

Luminosity frontier

- **Need corresponding rise in luminosity (beam intensity)**

$$N = \sigma L = \sigma \int \mathcal{L} dt$$

Number of events \downarrow Instantaneous luminosity \downarrow
 \downarrow \downarrow
 $N = \sigma L = \sigma \int \mathcal{L} dt$
 \uparrow \uparrow
 Cross section Integrated luminosity

- **High luminosity brings all the challenges for the detectors:**

- High event rates
- Pile up
- Beam –beam interactions
- Beamstrahlung

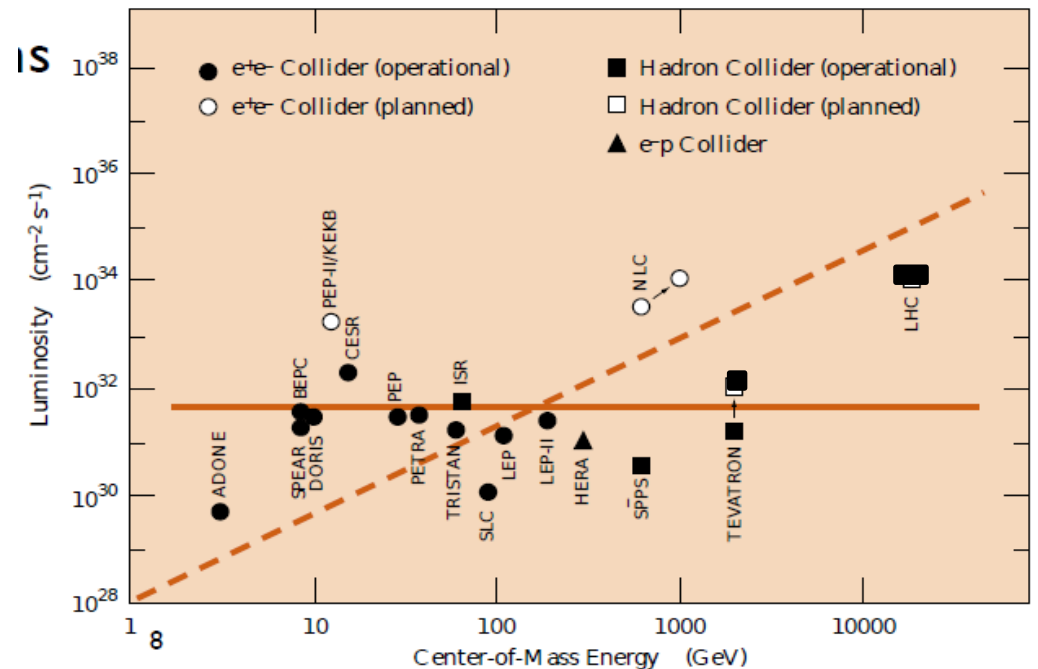

Designing a machine

- **Particle species**
 - Electron/**positrons**
 - Protons/antiprotons
 - **Muons/antimuons**
- **Beam energy**
- **Spin**
- **Luminosity**
- **How do you produce antiparticles?**
- **Ones produced how ones keep them (muon collider)?**
- **Ones collided what ones does with spent beams?**
- **Accelerator and detector protection**

Proton-proton collisions at LHC

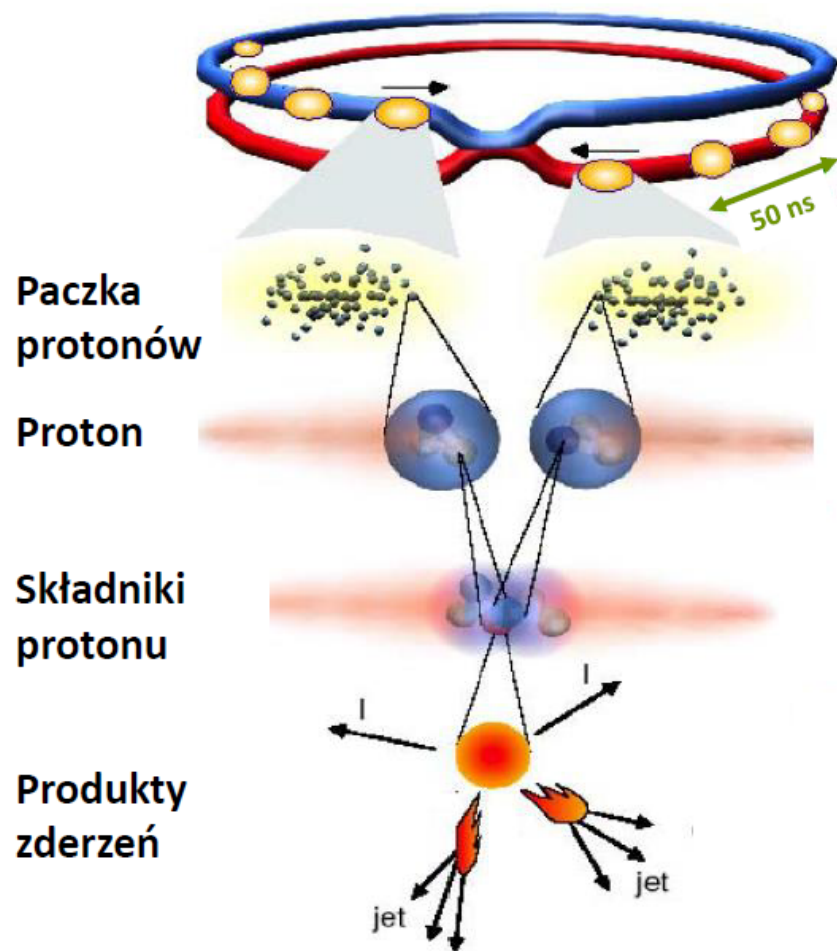

Proton-Proton	1380 paczek/wiązkę
Protonów/paczka	$1.7 \cdot 10^{11}$
Energia wiązki	3.5, 4.0, 6.5 TeV

Każdy proton porusza się z prędkością bliską prędkości światła i niesie kinetyczną energię muchy w locie, okrąża pierścień akceleratora 1100 razy na sekundę.

Rozmiar poprzeczny wiązki: $16 \mu\text{m}$ (4 razy mniejszy niż grubość ludzkiego włosa).
Każda z wiązek niesie energię pociągu TGV o dł. 200 m i jadącego z prędkością 155km/godz (360M Jula).

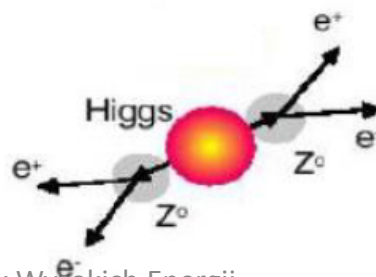

Takie zdarzenie pojawia się raz na 10 bilionów zderzeń

Complementarity between pp and ee machines

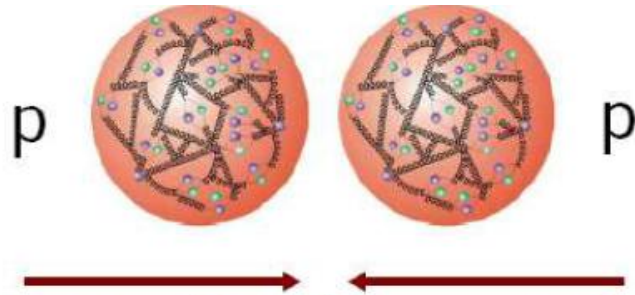

- Proton-(Anti-)Proton Colliders
 - Higher energy reach (limited by magnets)
 - Composite particles: unknown and different colliding constituents, energies in each collision
 - Confusing final states
- Discovery machines (W, Z, t)
- In some cases: precision measurements possible (W mass at the Tevatron)



- Electron-Positron-Colliders
 - Energy reach limited by RF
 - Point like particles, exactly defined initial system, quantum numbers, energy, spin polarisation possible
 - Hadronic final states with clear signatures
- Precision machines
- Discovery potential, but not at the energy frontier

Acceleration

Lorentz force law

$$\mathbf{F} = q (\mathbf{E} + \mathbf{v} \times \mathbf{B})$$

Electric field Velocity Magnetic field

Energy change

$$\Delta E = \int_{\mathbf{r}_1}^{\mathbf{r}_2} \mathbf{F} \cdot d\mathbf{r}$$

- Electric field (either static or more commonly, time varying) to accelerate, or more appropriately, increase energy of beam
- Magnetic part of Lorentz force used to guide and focus
 - Dipole magnets: to bend
 - Quadrupole: to focus or defocus

Synchrotron

- **Workhorse of modern particle physics**
 - Huge legacy of discovery
 - Increase energy whilst synchronously increasing bending magnet strength
 - Stable storage of high beam current/power
- **Magnetic field proportional to momentum**

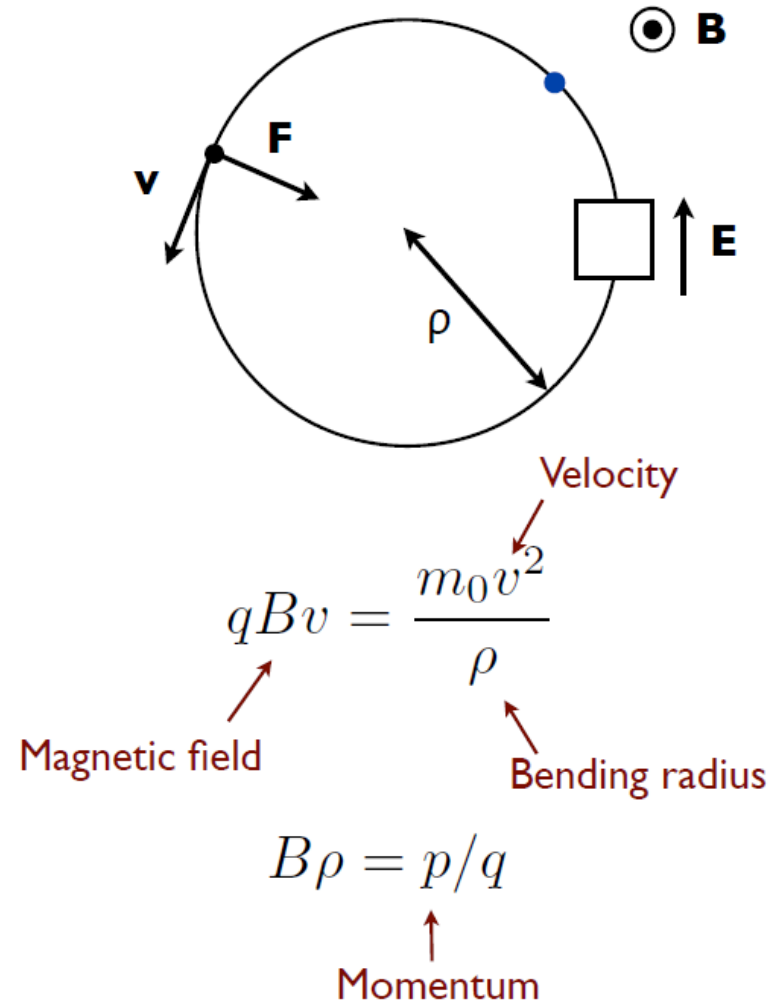

Accelerator is much more than just....

- **Particle production**
- **Damping, cooling or preparation**
- **Injection and extraction**
- **Acceleration**
- **Collimation (betatron, energy etc.)**
- **Diagnostics and controls**
- **Machine (and detector protection)**
- **Beam delivery and luminosity production**
- **Technology spin off**
 - **Lower energy machines, medical applications, applied physics, materials,**

Synchrotron + many passages in RF cavities

LHC **circular machine** with energy gain per turn ~ 0.5 MeV
acceleration from 450 GeV to 7 TeV will take about 20 minutes

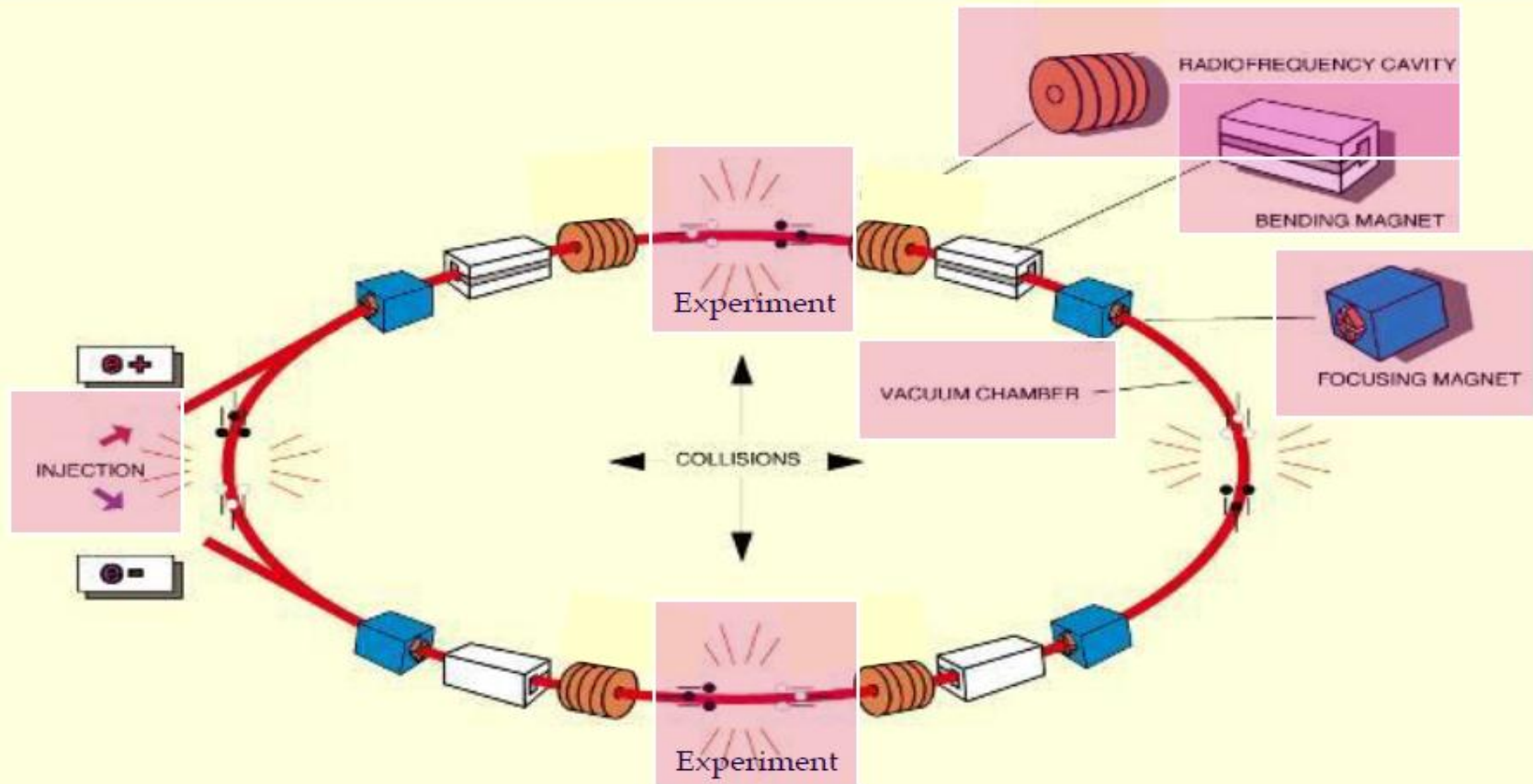

Superconducting magnets in LHC tunnel

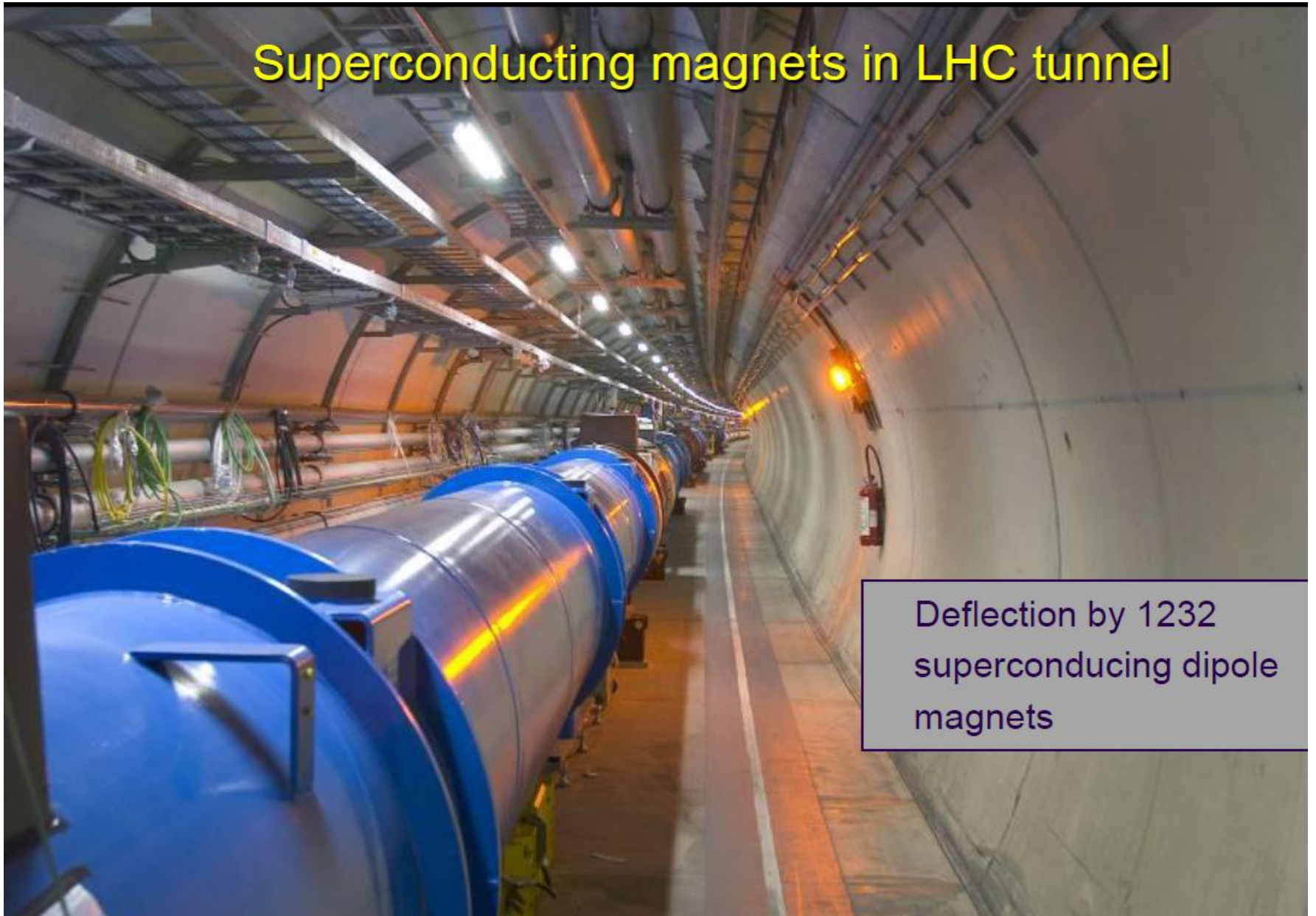

Deflection by 1232
superconducting dipole
magnets

Synchrotron

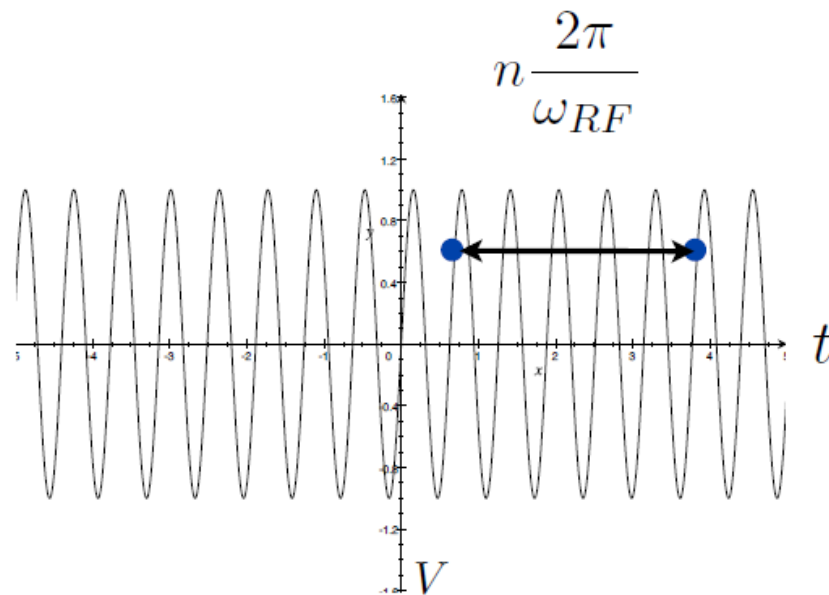
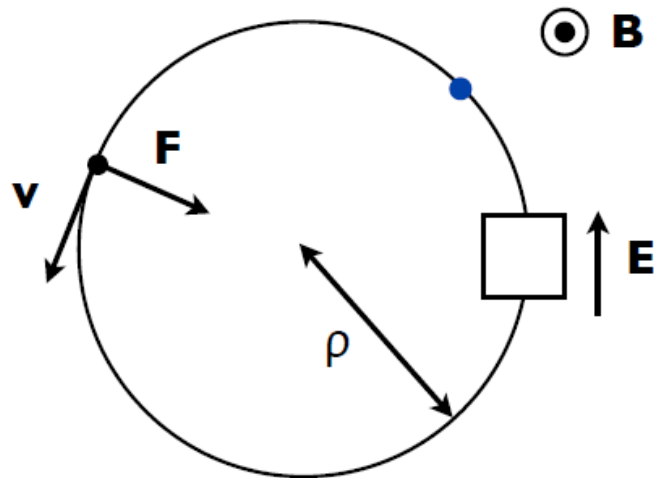

- Time varying electric field:

$$V(t) = V_0 \sin(\omega_{RF}t + \phi)$$

↑
Angular frequency of
accelerating field

- Particle gets a kick every revolution

$$\frac{1}{f_{\text{ref}}} = n \frac{2\pi}{\omega_{RF}}$$

↑
Revolution
frequency

↑
Integer

Synchrotron Radiation Limits

- Why not just build bigger LEP?
- Reuse accelerating section every revolution of particle bunch
- Power loss due to synchrotron radiation
- LEP2 was practical limit for electron-positron synchrotron

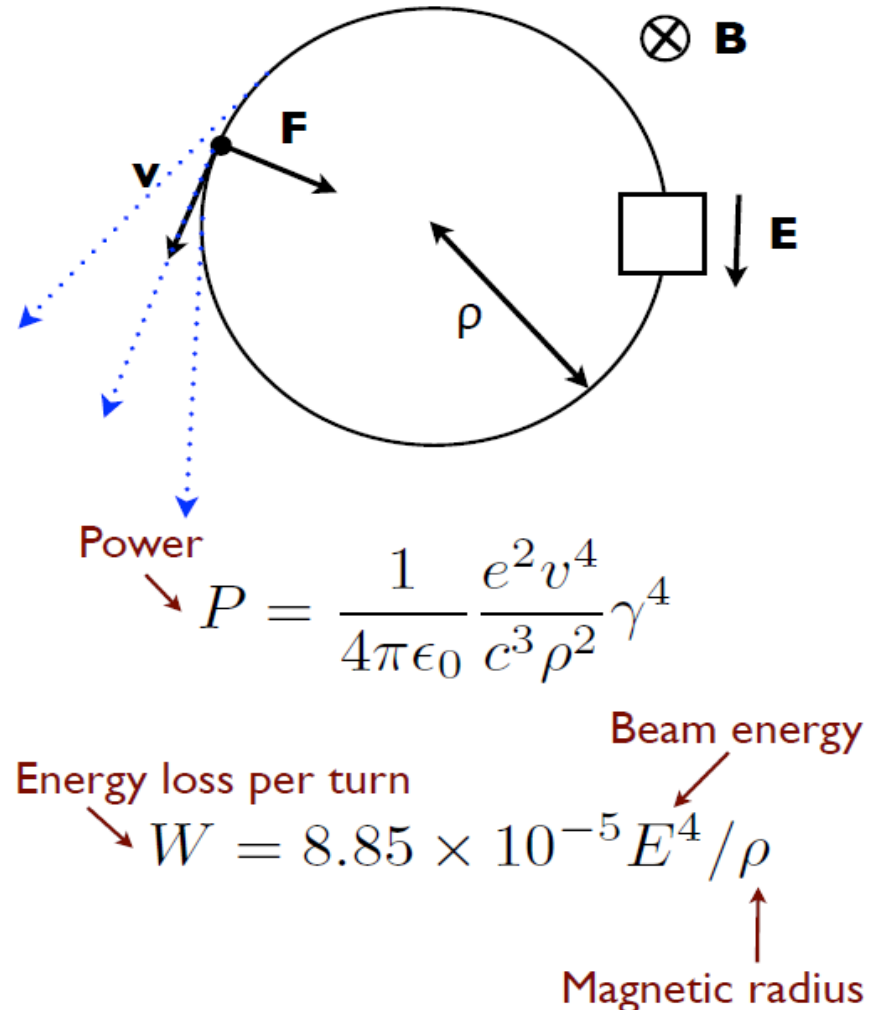

Absolute Limits on Acceleration

- Need to create large on axis electric fields
- Accelerating structures:
 - Superconducting (~35 MV/m)
 - Normal conducting (~100 MV/m)
- Beyond these values there is high voltage breakdown

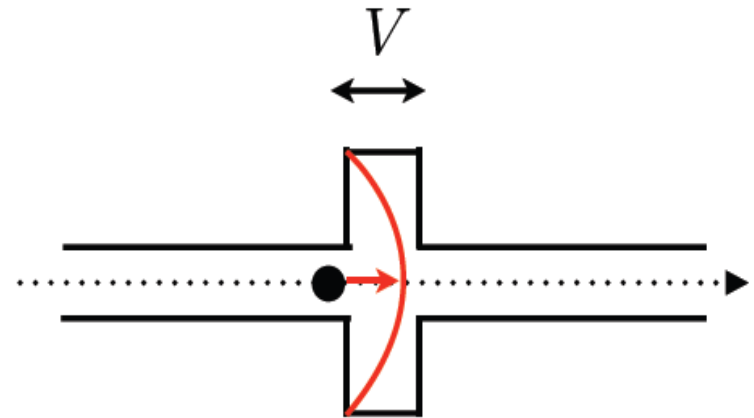

$$S = \frac{E}{q \frac{dV}{ds}}$$

Machine length [m] Beam energy [MeV]

↑
Accelerating gradient [MV/m]

RF systems: 400 MHz

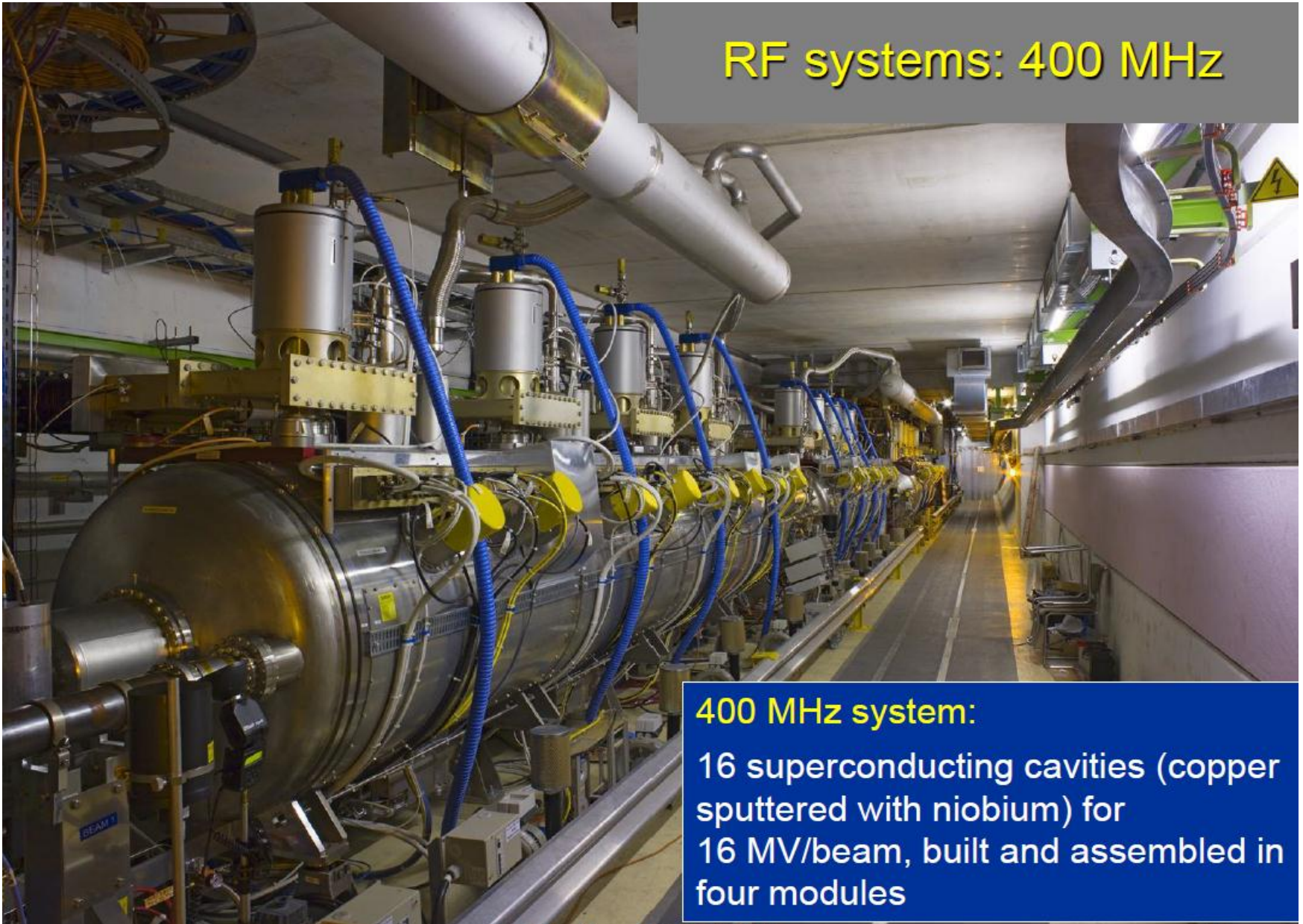

400 MHz system:

16 superconducting cavities (copper sputtered with niobium) for 16 MV/beam, built and assembled in four modules

Principle of a synchrotron

- Injection at low energy.
- Ramping of magnetic field and acceleration by RF field. Beams are accelerated in bunches.
- Operation (collisions) at top energy.

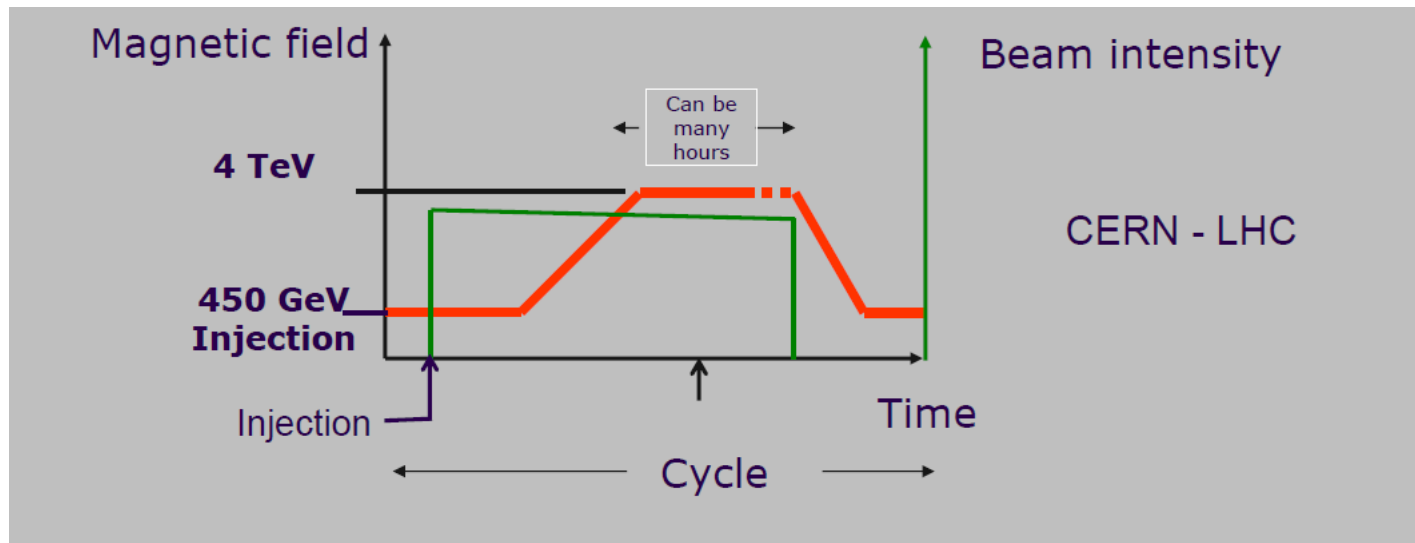

CERN accelerator complex

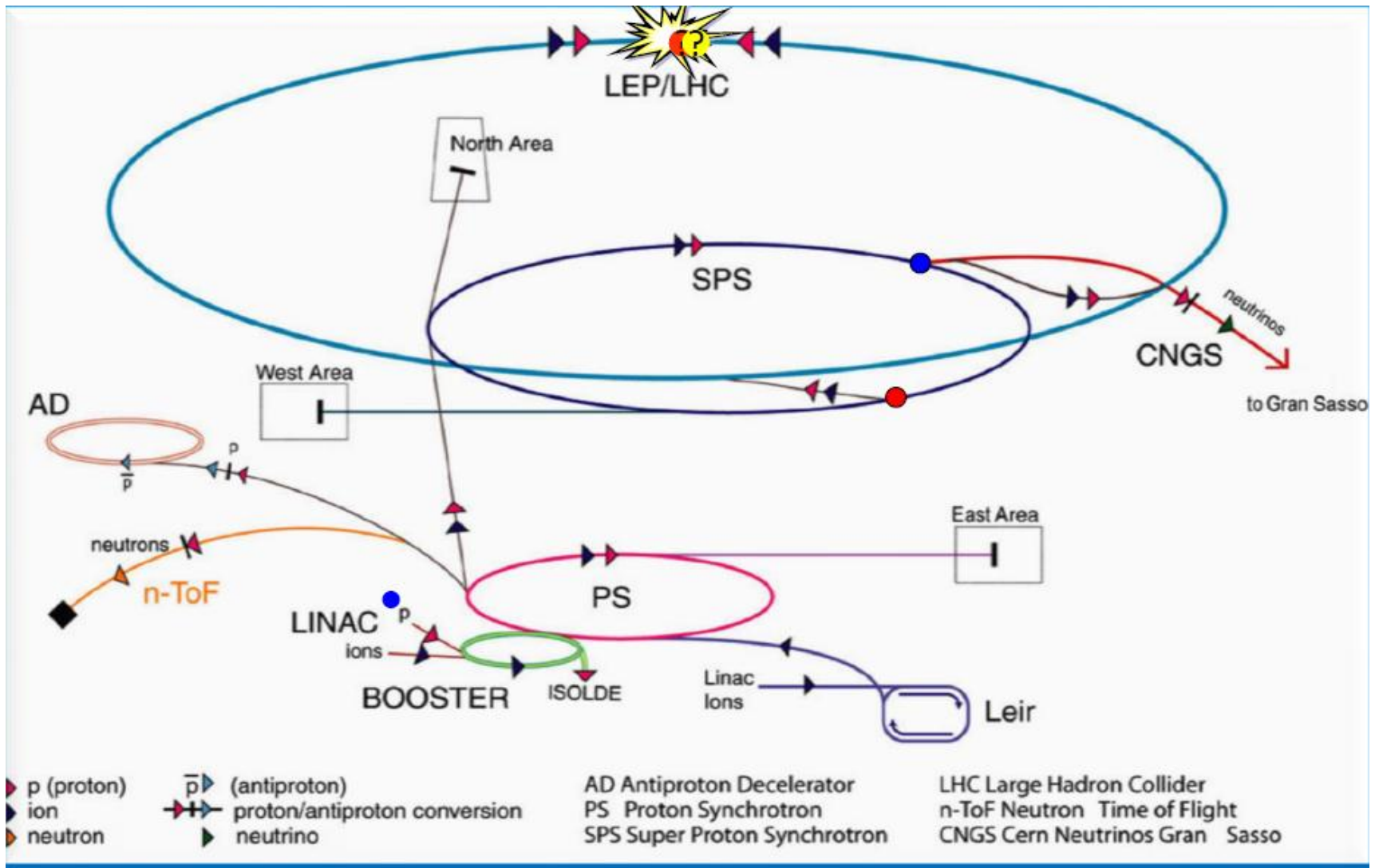

Experimental long straight section

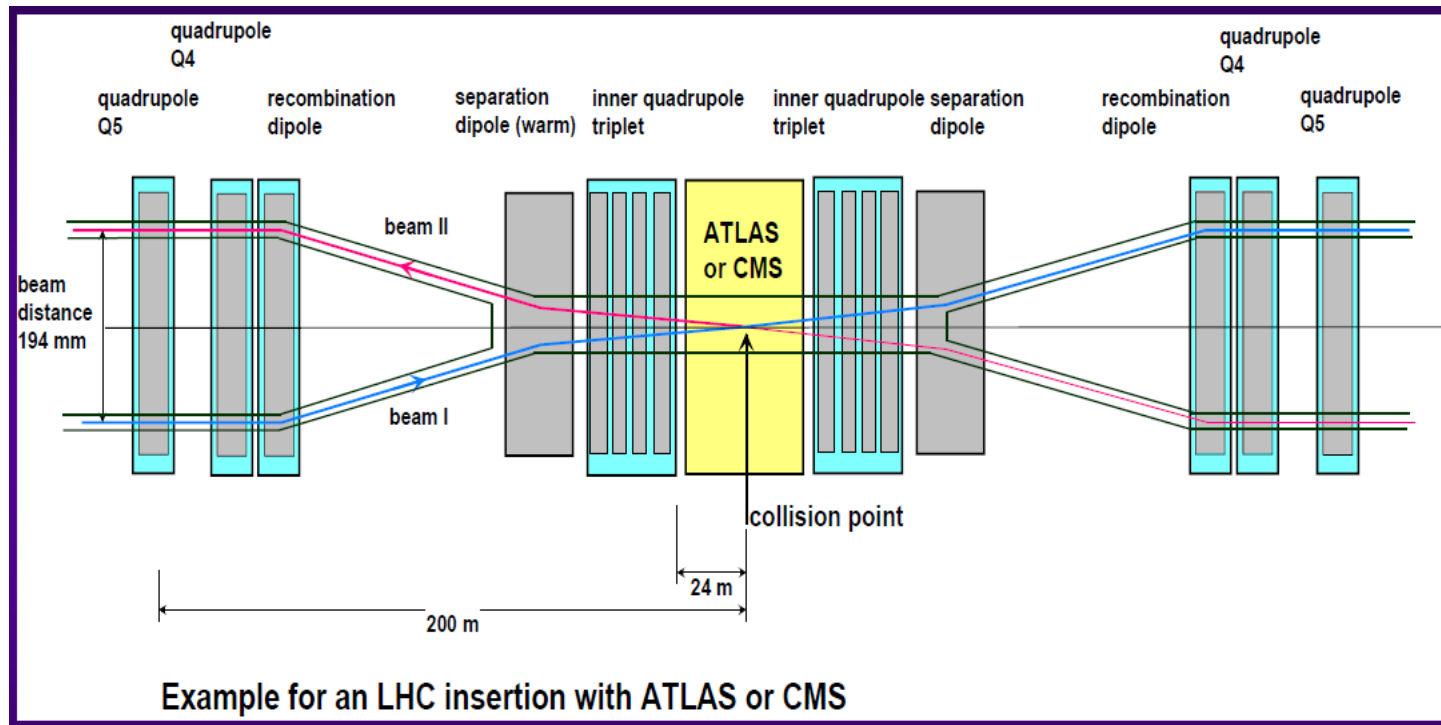

The 2 LHC beams are brought together to collide in common region. Over ~260m the beams circulate in one vacuum chamber with „parasitic” encounters.

The crossing angle of about $300\mu\text{rad}$

Luminosity

- What luminosity is required for measurement?
- Need some knowledge of x-section
- Simple relationship between number of particles, frequency of collision and beam sizes

$$\mathcal{L} = f \frac{N_1 N_2}{4\pi\sigma_x\sigma_y}$$

Luminosity [$s^{-1} m^{-2}$] Bunch populations
 Frequency of collisions [Hz] Beam r.m.s. sizes [m]

$$\sigma = \sqrt{\epsilon\beta}$$

Emittance [m] Beta function [m]

$$\mathcal{L} = f \frac{N_1 N_2}{4\pi \sqrt{\epsilon_x \beta_x^* \epsilon_y \beta_y^*}}$$

CMS

E
CMS Experiment at LHC, CERN
Data recorded: Mon May 28 01:16:20 2012 CERN
Run/Event: 195099 / 35488125
Lumi Section: 65
Orbit/Crossing: 16992111 / 2295

- ⇒ With the parameters of 2012 for each bunch crossing there are up to ~35 interactions (lower luminosity, less number of bunches)
- ⇒ 'Hats off' to ATLAS & CMS for handling this pile-up !!

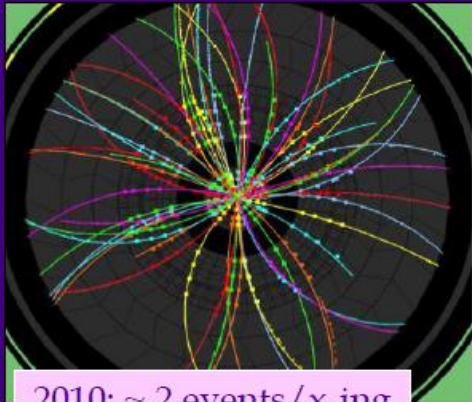

2010: ~ 2 events/x-ing

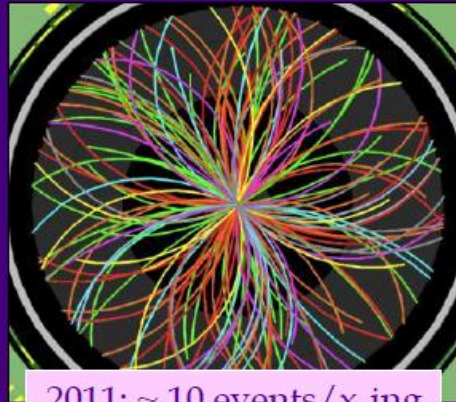

2011: ~ 10 events/x-ing



2012: ~ 20 events/x-ing

Layout of beam system dump

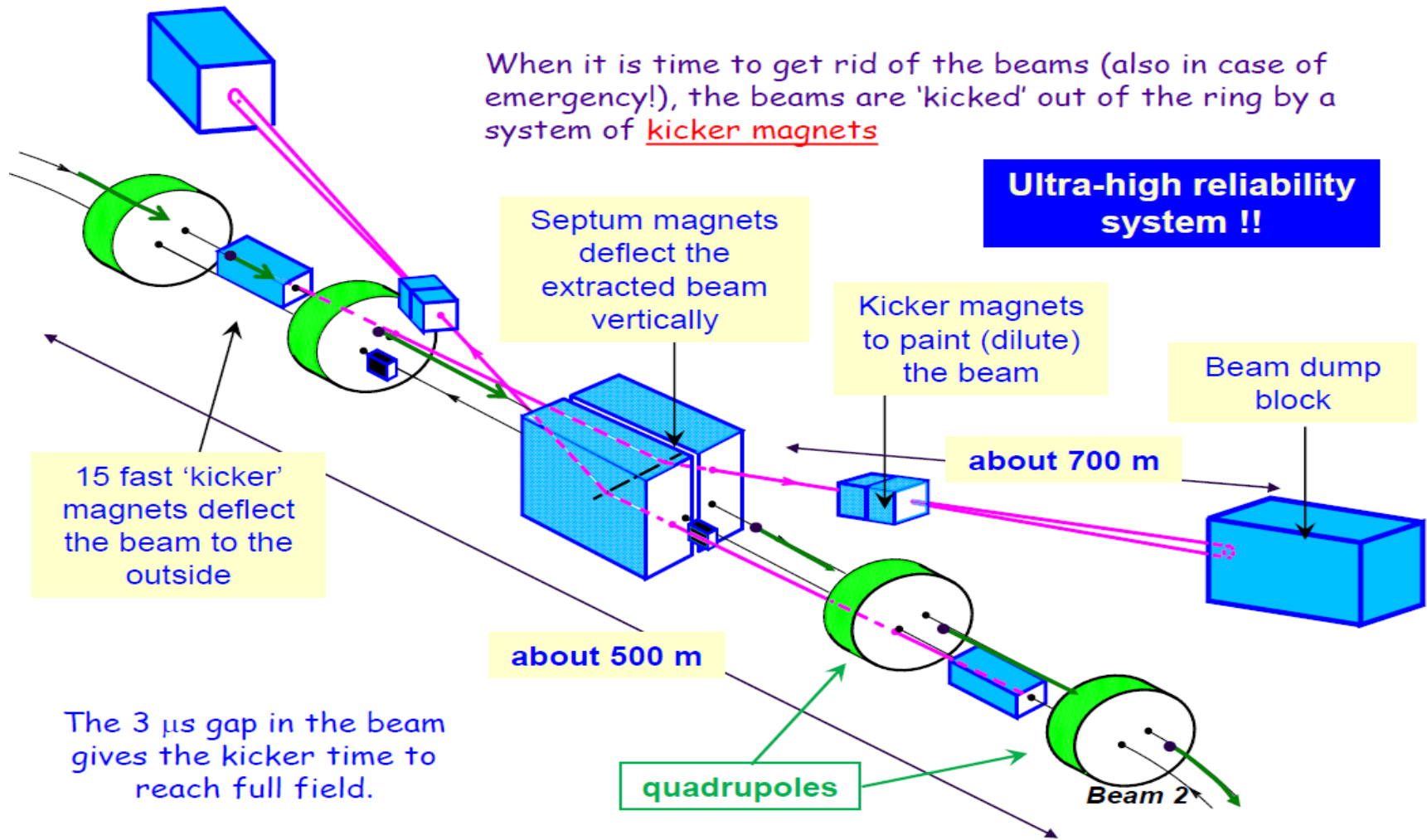



Dump line



Beam Loss Monitors

- Ionization chambers to detect beam losses:
 - Reaction time $\sim \frac{1}{2}$ turn ($40 \mu\text{s}$)
 - Very large dynamic range ($> 10^6$)
- There are **~ 3600 chambers** distributed over the ring to detect abnormal beam losses and if necessary trigger a beam abort !
- Very important beam instrumentation!



Energy frontiers

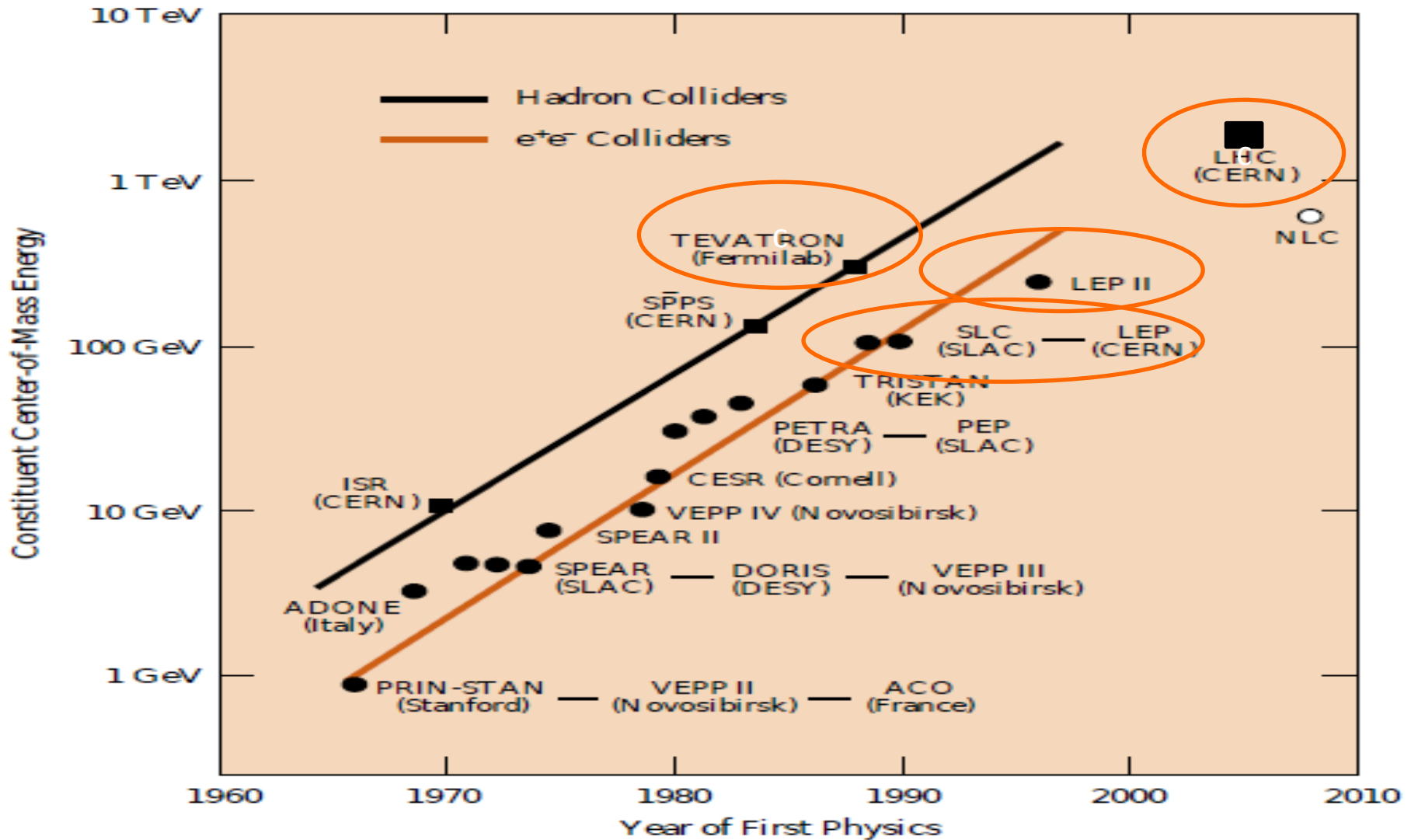

Accelerators around the world (past and present)



CERN accelerator complex

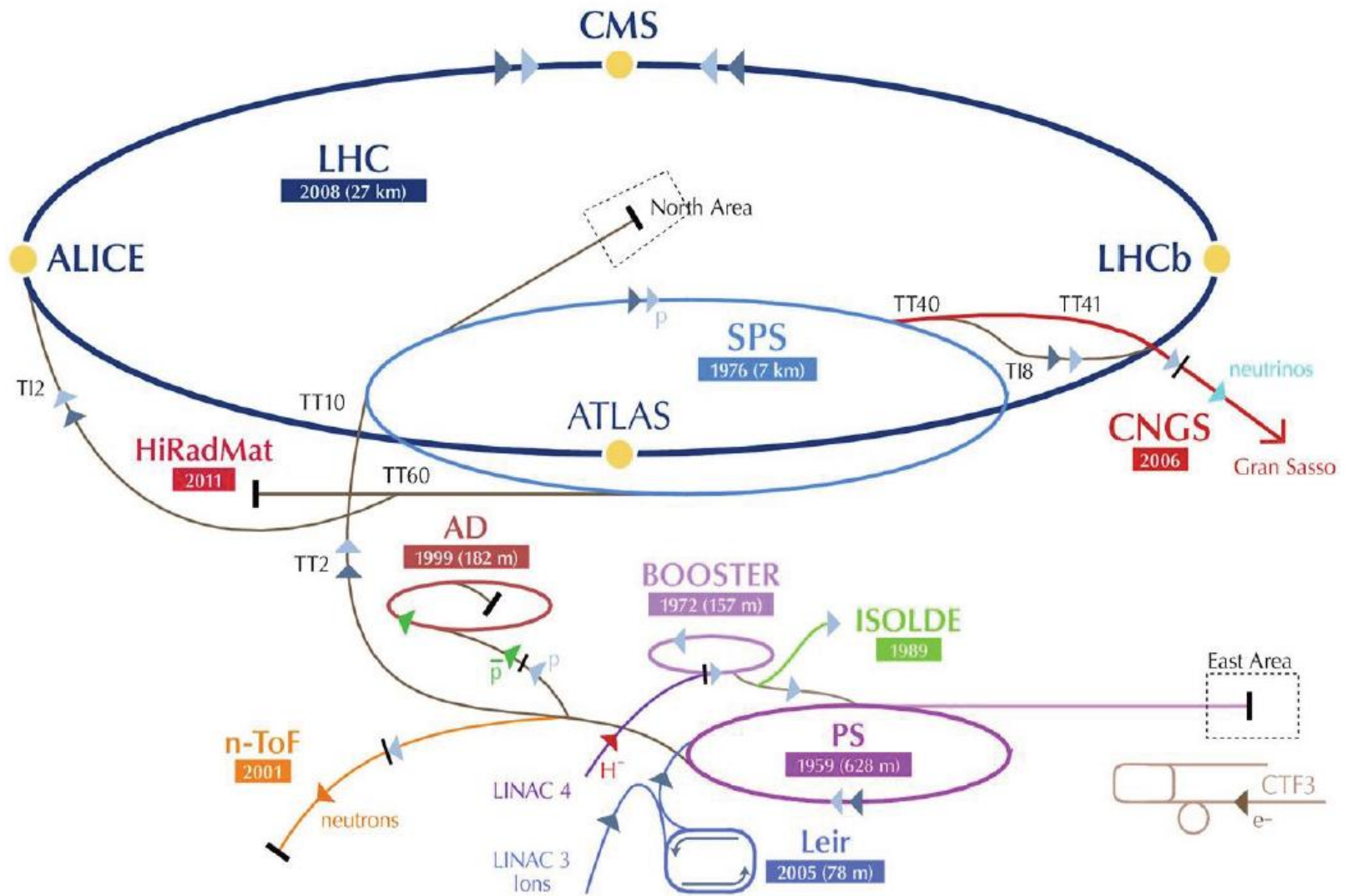

CERN, Szwajcaria

LEP

e^+e^- collider (1998-2000)

$\sqrt{s} = 91 \text{ GeV}$ (LEP)

$\sqrt{s} \sim 200 \text{ GeV}$ (LEP2)

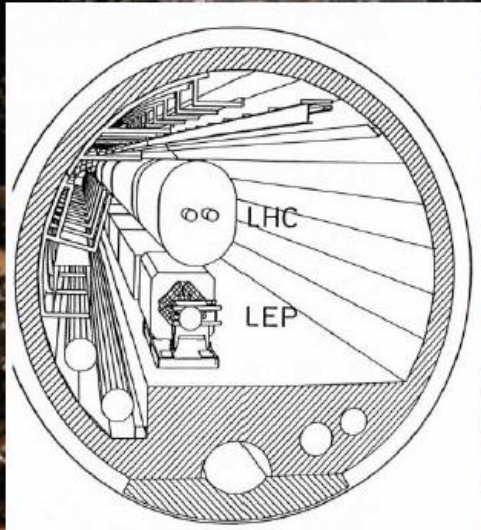

Experimental Areas at SLAC

Linac 50 GeV
 SPEAR 4 x 4 (1/2 SSRL)
 PEP 20 x 20
 PEP-II 9 x 3.1
 SLC 50 x 50

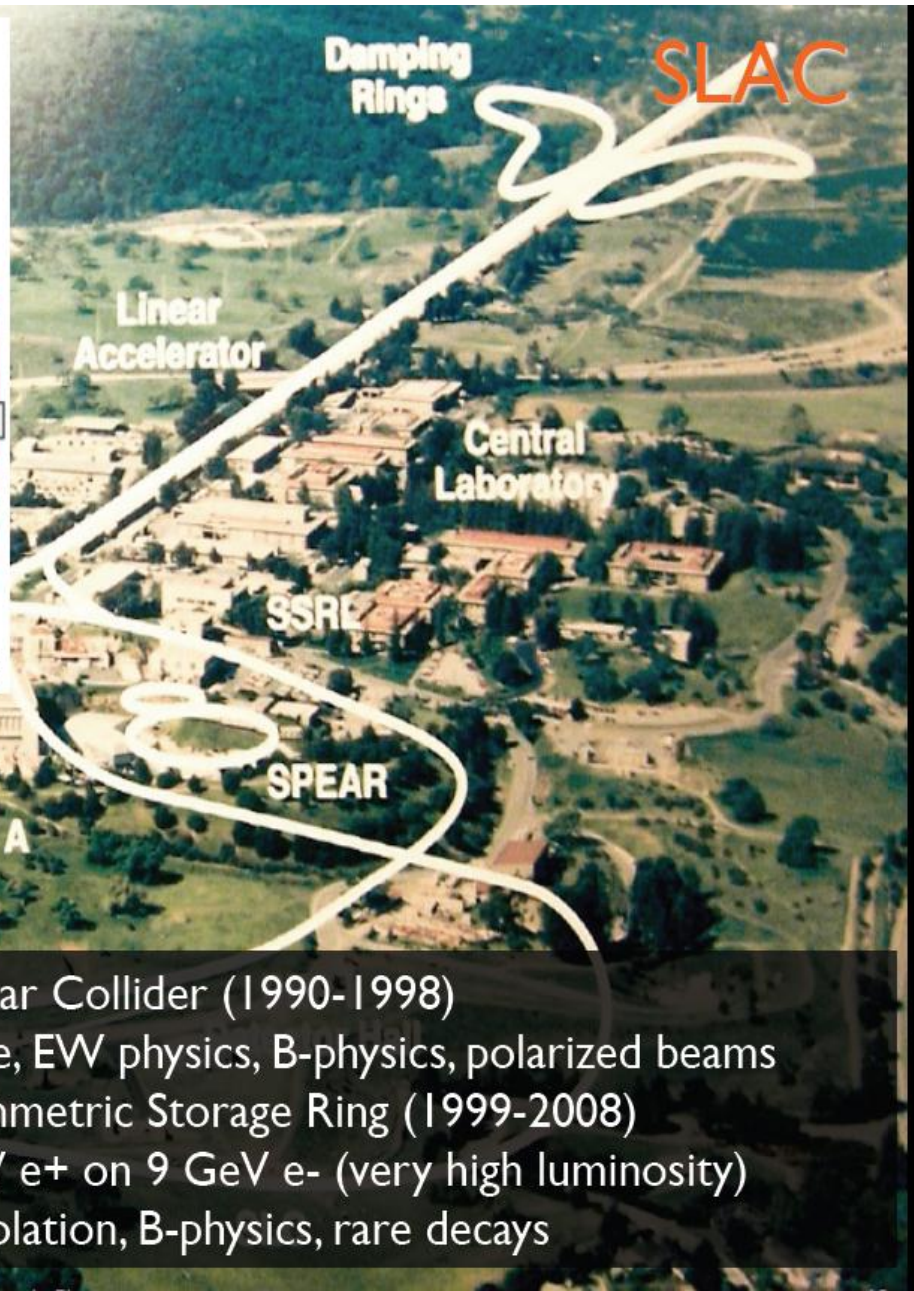
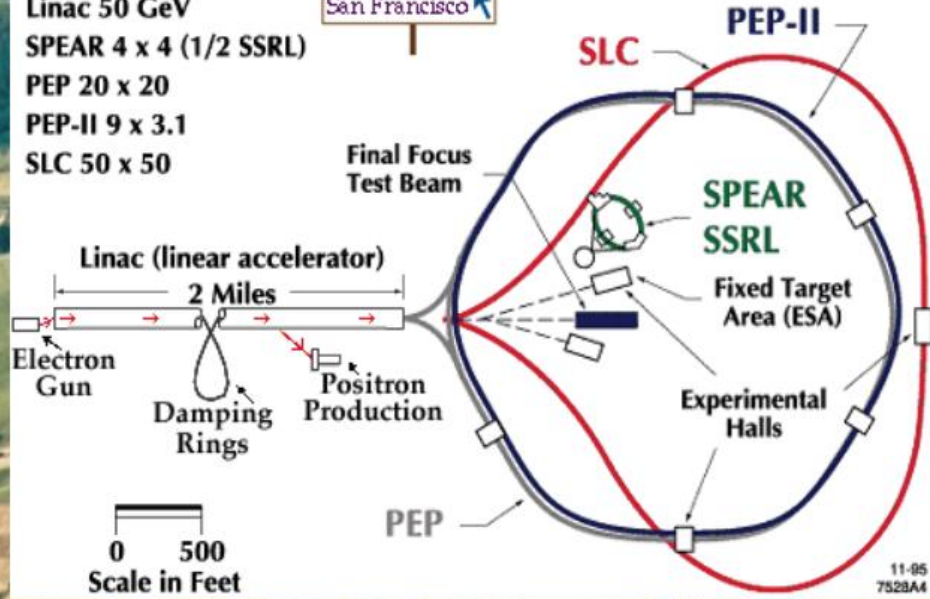
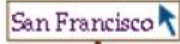

SLAC Linear Collider (1990-1998)
 Z-pole, EW physics, B-physics, polarized beams
 PEP-II Asymmetric Storage Ring (1999-2008)
 3 GeV e⁺ on 9 GeV e⁻ (very high luminosity)
 CP Violation, B-physics, rare decays

HERA

Hamburg, Germany

e^{\pm} -p collider (1992-2007)
 $\sqrt{s} = 318 \text{ GeV}$

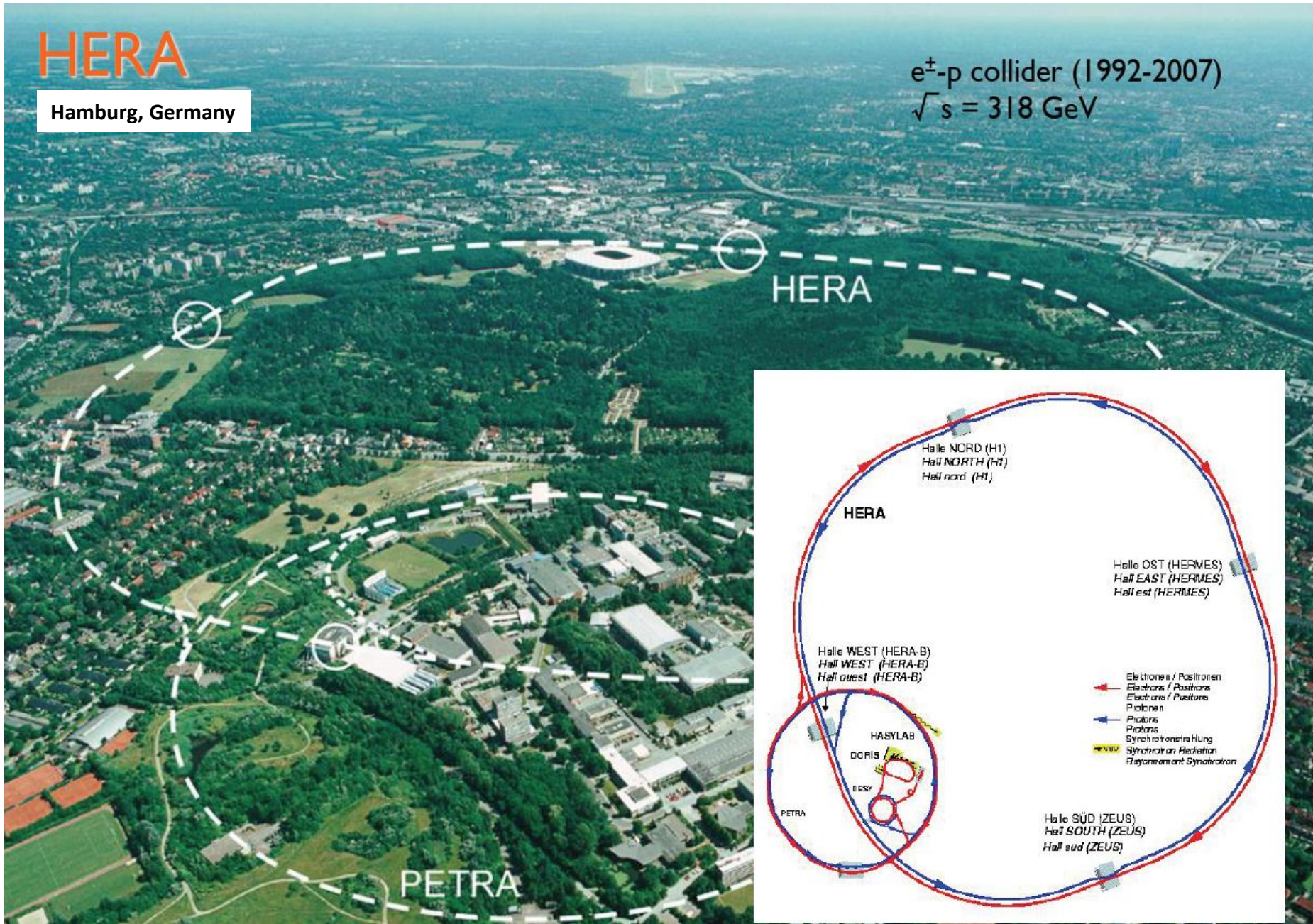

Tevatron

Fermilab, USA

$p\bar{p}$ collider (1983-2011)
 $\sqrt{s} = 1.96 \text{ TeV}$

CDF-D0

top quark discovery
Higgs search
new physics

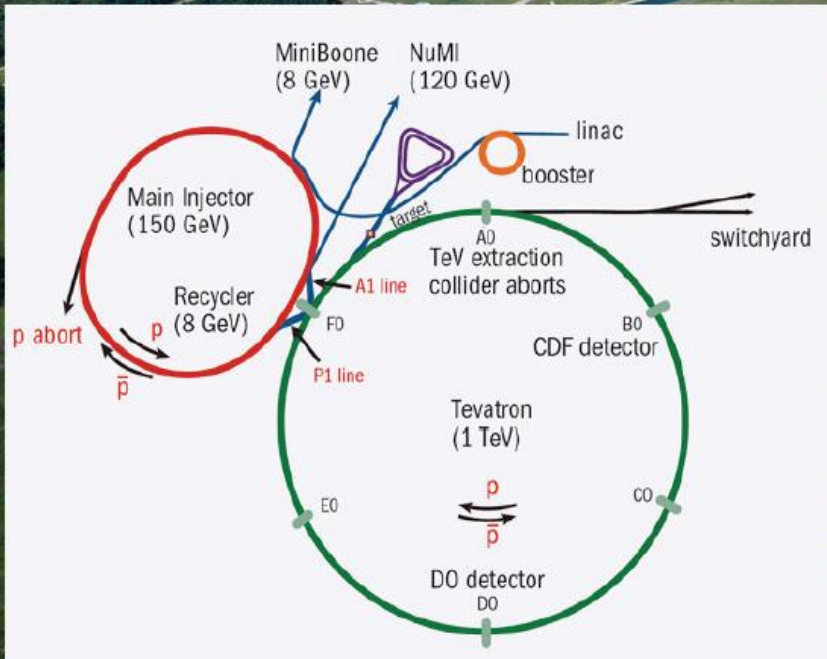

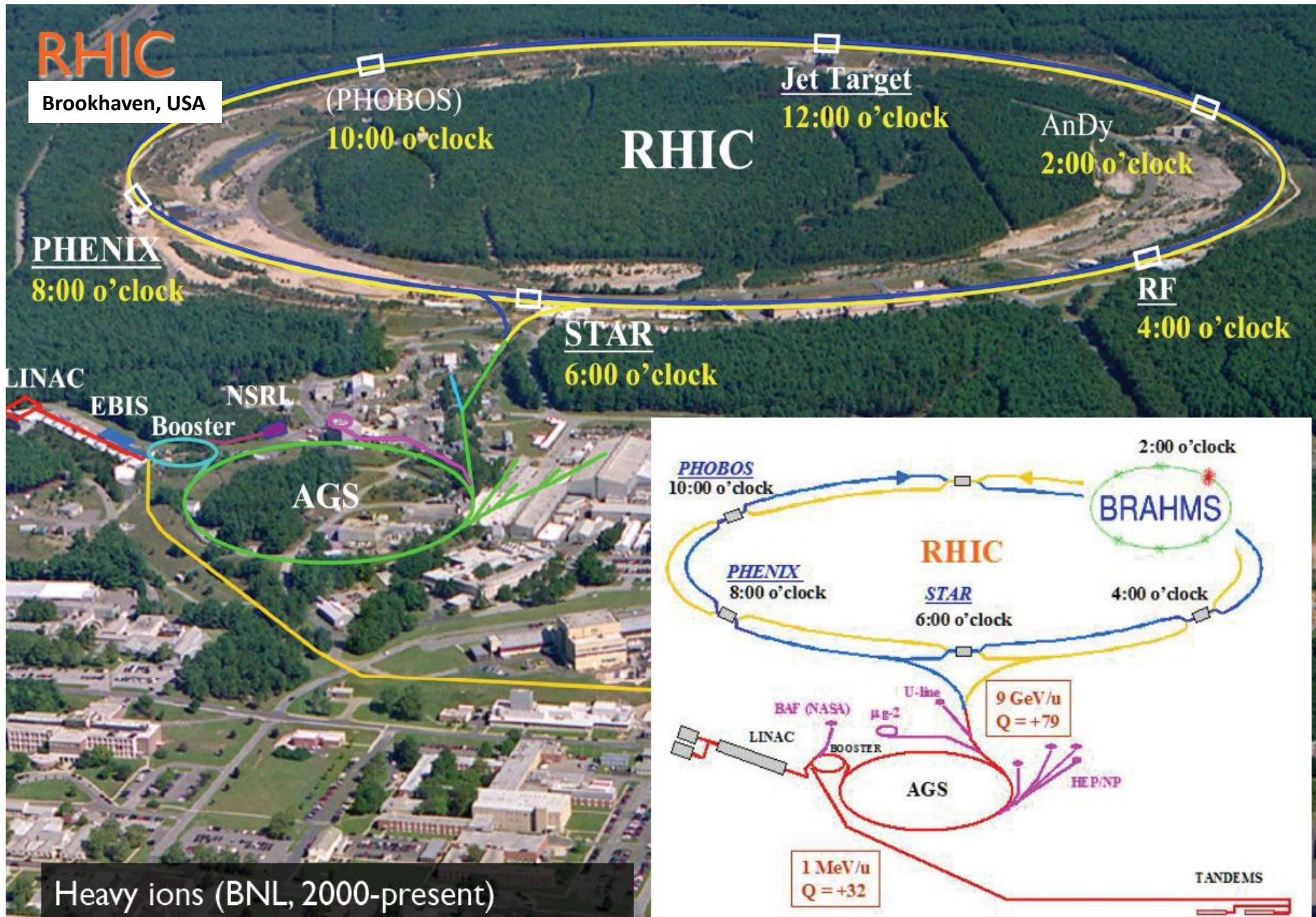

LHC (Large Hadron Collider)

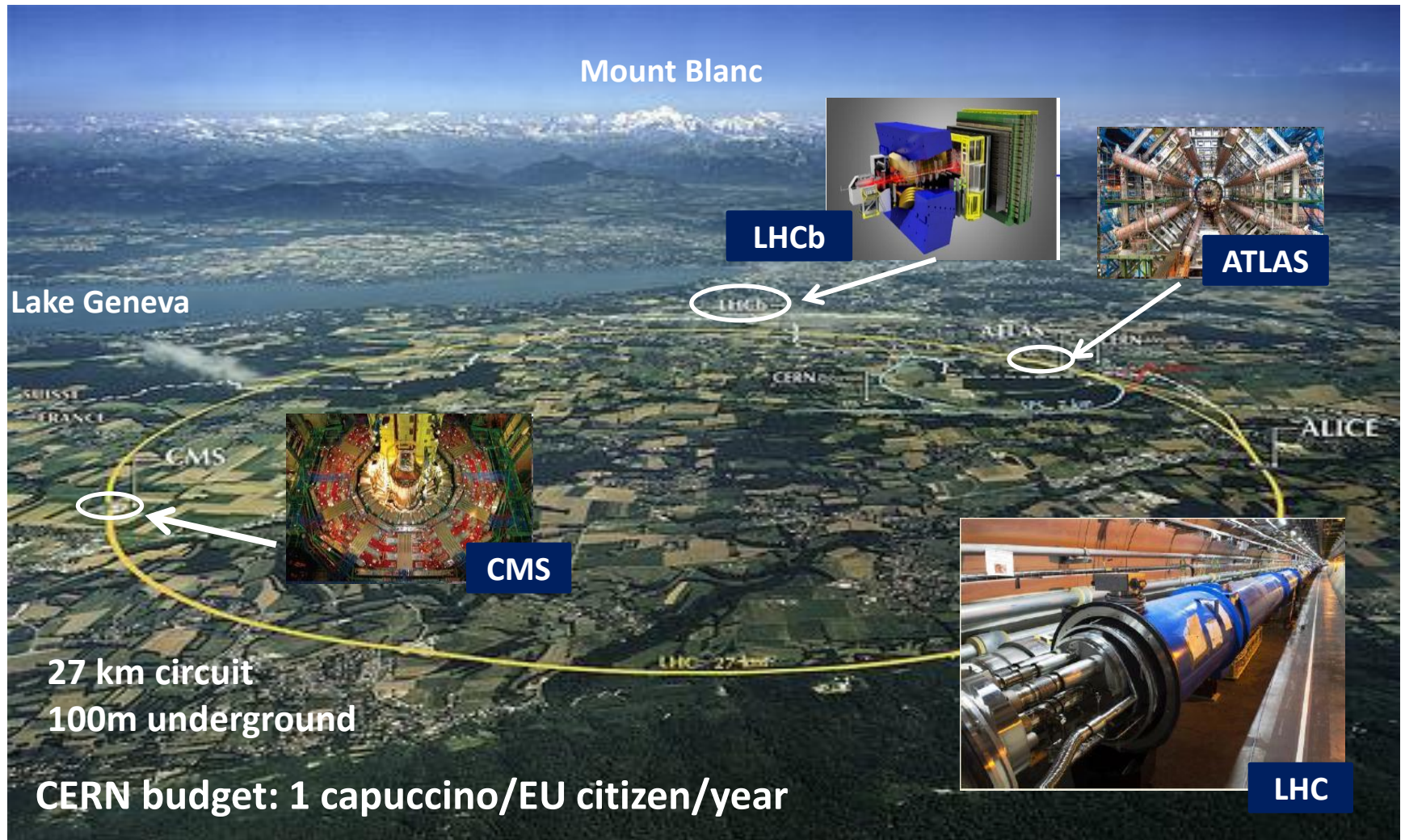

One of the most ambitious projects in Science

The LHC: just another collider?

	Start	Type	Max proton energy [GeV]	Length [m]	B Field [Tesla]	Lumi [cm ⁻² s ⁻¹]	Stored beam energy [MJoule]
TEVATRON Fermilab Illinois USA	1983	p-pbar	980	6300	4.5	4.3 10 ³²	1.6 for protons
HERA DESY Hamburg	1992	p – e+ p – e-	920	6300	5.5	5.1 10 ³¹	2.7 for protons
RHIC Brookhaven Long Island	2000	Ion-Ion p-p	250	3834	4.3	1.5 10 ³²	0.9 per proton beam
LHC CERN	2008	Ion-Ion p-p	7000 Now 6500	26800	8.3	10 ³⁴	362 per beam
Factor			7	4	2	50	100

LHC energy evolution

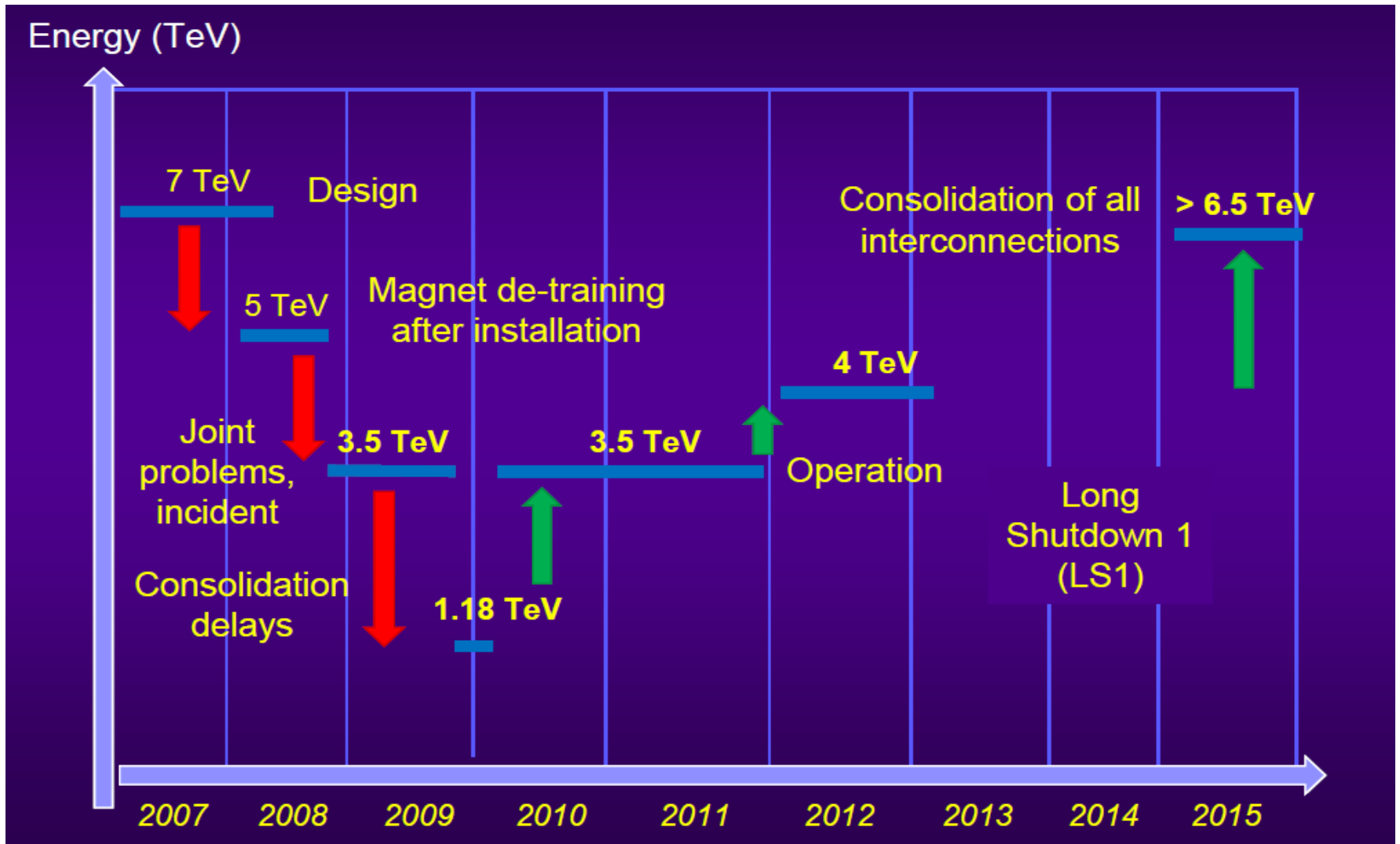

Summary: 2010 - 2012

$$L = \frac{k N_b^2 f \gamma}{4\pi \beta^* \varepsilon^*} F$$

Parameter	2010	2011	2012	Nominal
Energy [TeV]	3.5	3.5	4.0	7.0
N_b [10^{11} p/bunch]	1.2	1.45	1.6	1.15
k (no. bunches)	368	1380	1380	2808
Bunch spacing [ns]	150	75 / 50	50	25
Stored energy [MJ]	25	112	140	362
ε^* [μm]	2.4	2.4	2.5	3.75
β^* [m]	3.5	1.5 \rightarrow 1	0.6	0.55
Crossing angle [μrad]	200	240	290	285
L [10^{34} $\text{cm}^{-2}\text{s}^{-1}$]	0.02	0.35	0.76	1.0
Beam-beam parameter/IP (ΔQ_{bb})	-0.0054	-0.0065	-0.0069	-0.0033
Average Pile-up @ beg. of fill	8	17	38	26

Improvements to luminosity

increase number of bunches?

increase number particle per bunch?

$$\mathcal{L} = \frac{1}{4\pi} \frac{f k N_1 N_2}{\sqrt{\epsilon_x \beta_x^* \epsilon_y \beta_y^*}}$$

decrease emittance!

decrease beta star!

Improvements to luminosity

Data included from 2010-03-30 11:22 to 2016-10-27 14:12 UTC

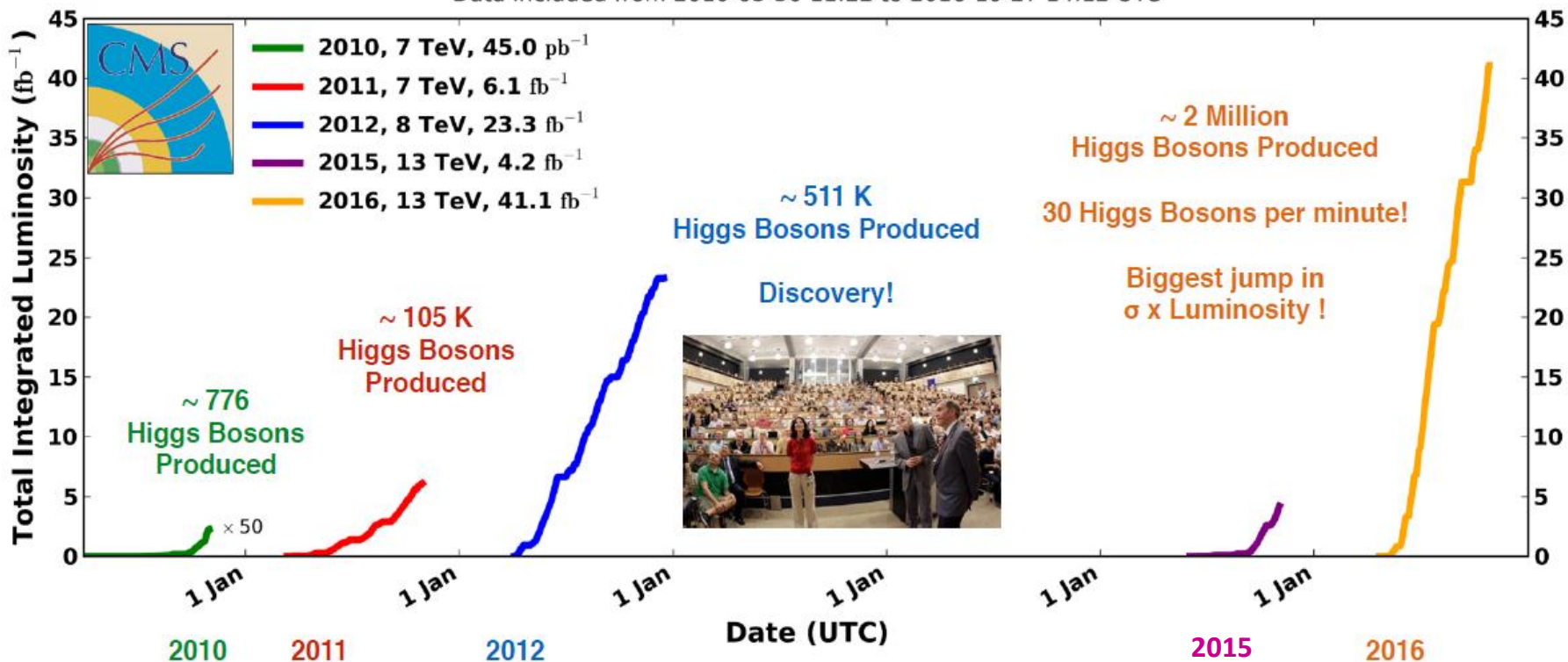

Large Hadron Collider will operate till 2035

Only 2% of complete LHC/HL-LHC has been delivered to date.

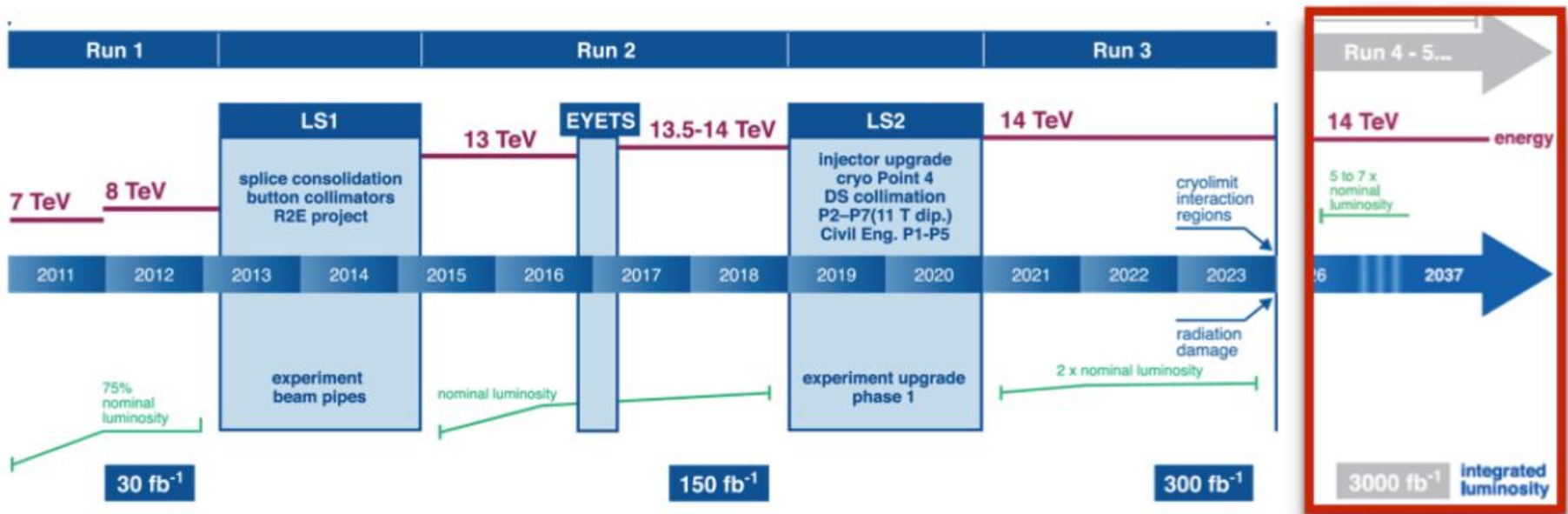

ECFA report 2016 (European Committee for Future Accelerators)

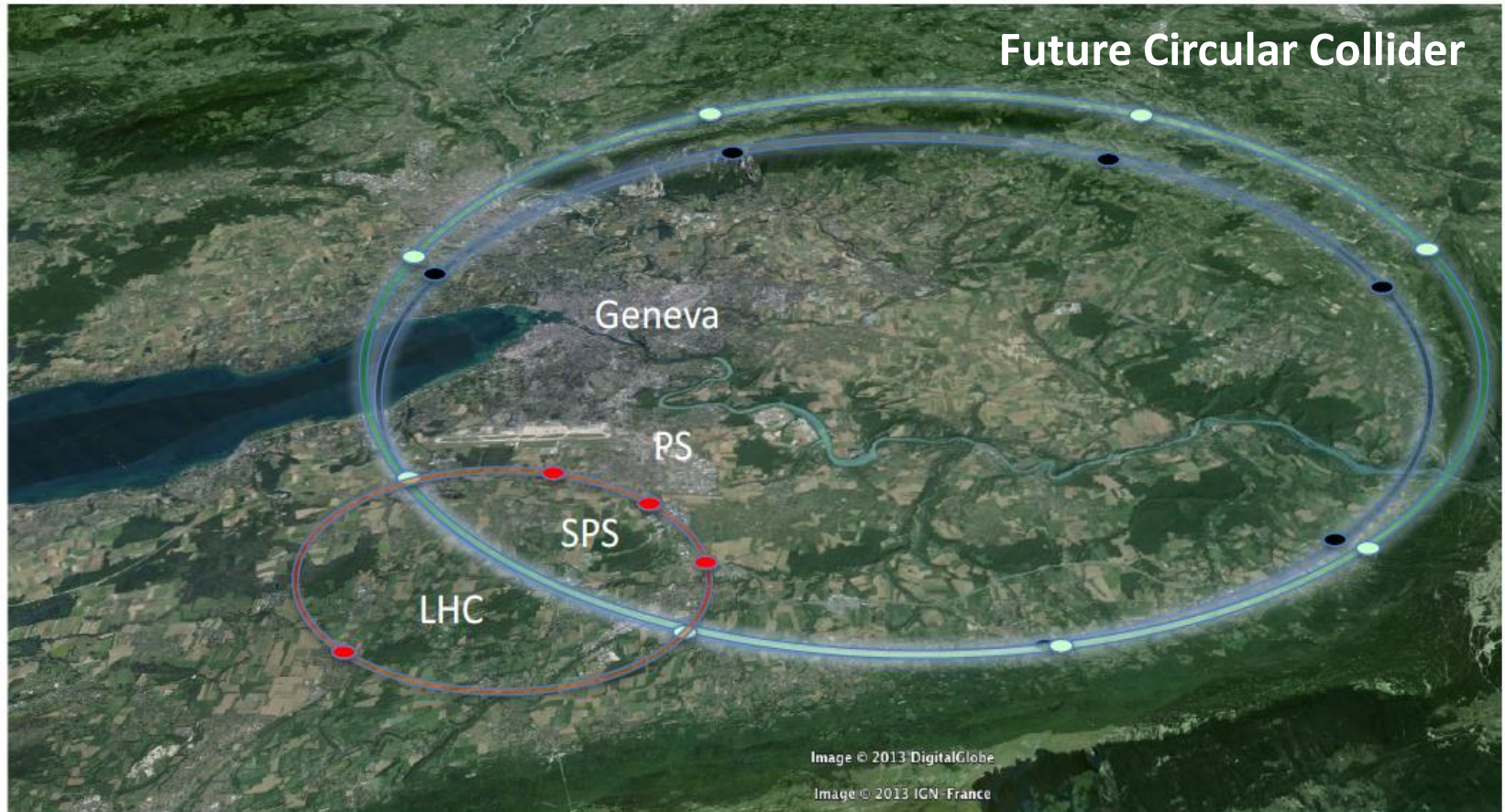

LHC
27 km, 8.33 T
14 TeV (c.o.m.)

HE-LHC
27 km, **20 T**
33 TeV (c.o.m.)

FCC-hh
80 km, **20 T**
100 TeV (c.o.m.)

FCC-hh
100 km, **16 T**
100 TeV (c.o.m.)

Additional material

A brief history of particle accelerators

- 1924 Ising proposes time-varying fields across drift tubes. This is "resonant acceleration", which can achieve energies above that given by the highest voltage in the system.
- 1928 Wideröe demonstrates Ising's principle with a 1 MHz, 25 kV oscillator to make 50 keV potassium ions.
- 1929 Lawrence, inspired by Wideröe and Ising, conceives the cyclotron.
- 1931 Livingston demonstrates the cyclotron by accelerating hydrogen ions to 80 keV.
- 1932 Lawrence's cyclotron produces 1.25 MeV protons and he also splits the atom just a few weeks after Cockcroft and Walton (Lawrence received the Nobel Prize in 1939).

- 1923 Wideröe, a young Norwegian student, draws in his laboratory notebook the design of the betatron with the well-known 2-to-1 rule. Two years later he adds the condition for radial stability **but does not publish**.
- 1927 Later in Aachen Wideröe makes a model betatron, but it does not work. Discouraged he changes course and builds the linear accelerator mentioned in Table 2.
- 1940 Kerst re-invents the betatron and builds the first working machine for 2.2 MeV electrons.
- 1950 Kerst builds the world's largest betatron of 300 MeV.

A brief history of particle accelerators

1895	Lenard. Electron scattering on gases (Nobel Prize).	< 100 keV electrons. Wimshurst-type machines.
1913	Franck and Hertz excited electron shells by electron bombardment.	
1906	Rutherford bombards mica sheet with natural alphas and develops the theory of atomic scattering.	Natural alpha particles of several MeV
1911	Rutherford publishes theory of atomic structure.	
1919	Rutherford induces a nuclear reaction with natural alphas.	
	... Rutherford believes he needs a source of many MeV to continue research on the nucleus. This is far beyond the electrostatic machines then existing, but ...	
1928	Gamov predicts tunnelling and perhaps 500 keV would suffice ...	
1928	Cockcroft & Walton start designing an 800 kV generator encouraged by Rutherford.	
1932	Generator reaches 700 kV and Cockcroft & Walton split lithium atom with only 400 keV protons. They received the Nobel Prize in 1951.	

Cockcroft and Walton's apparatus

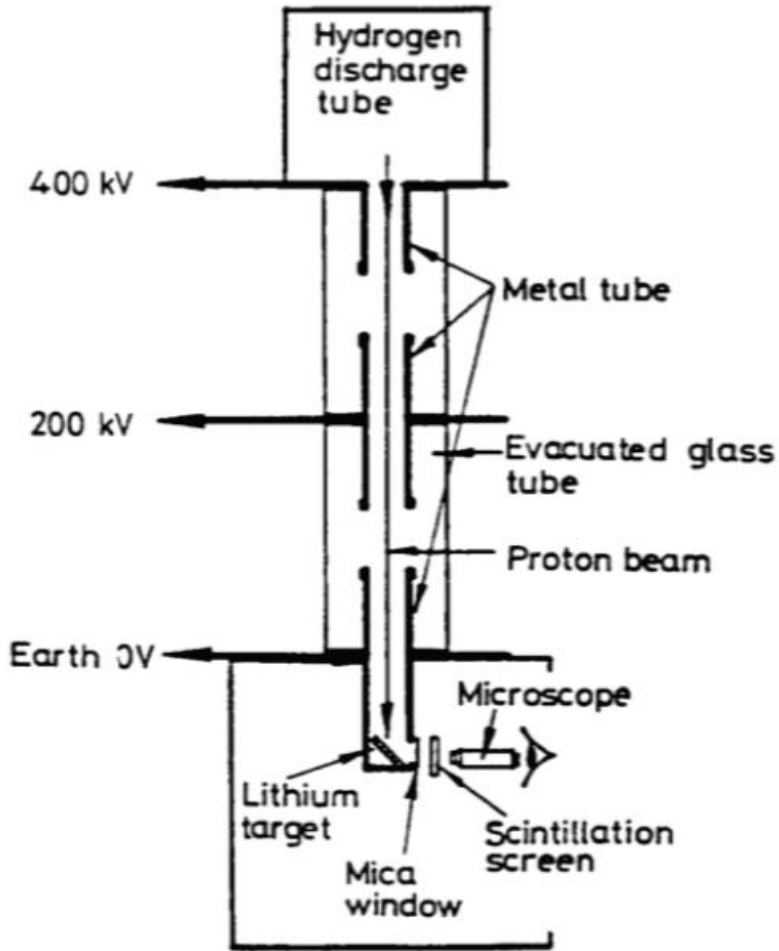

(a) Accelerating column

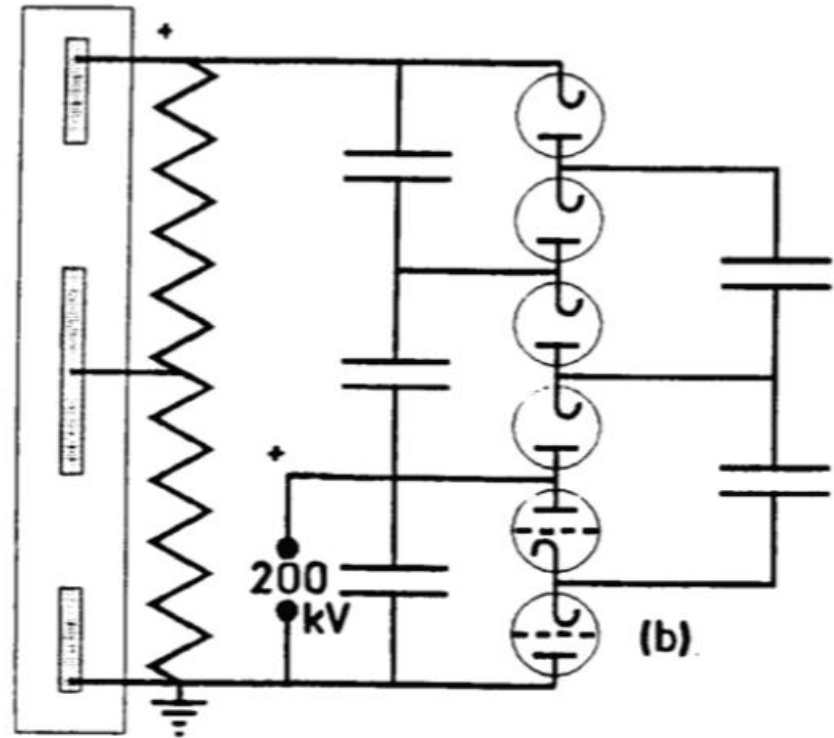

(b) DC generator

Van de Graaff electrostatic generator

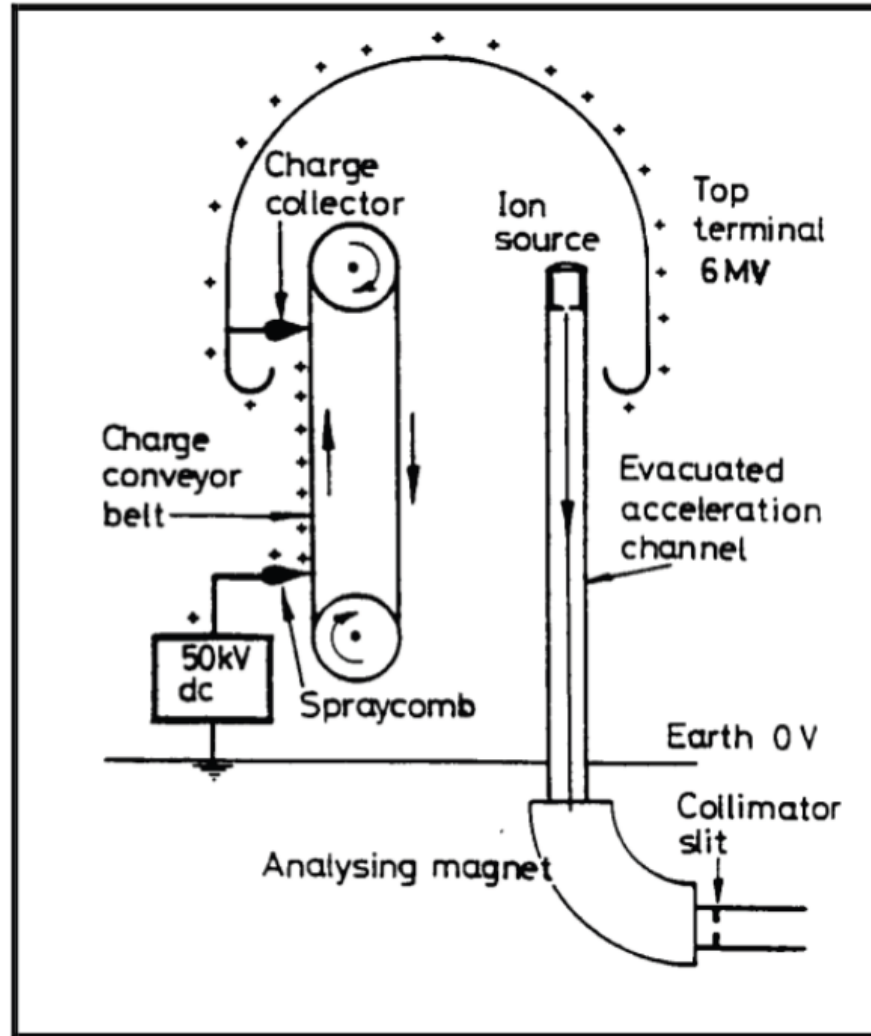

Two-stage Tandem accelerator

